



Operating Instructions
And
Owner's Manual

PRESSURE STORM SERIES

Q1325/Q1500

Q2265

Q2265E

Q2865

Q3370

Q3370E

Chongqing Lifan Suzhui Foreign Trade Co., Ltd.

All persons to whom you rent/loan this pressure washer to must have access to and read this manual. Keep this owner's manual with the pressure washer at all times and advise all persons who will operate the machine to read it. You must also provide personal instruction on how to safely set-up and operate the pressure washer and remain available to answer any questions a renter/borrower might have.

Only Trained Adults should set up and operate the Pressure Washer. DO NOT LET CHILDREN OPERATE THIS EQUIPMENT!!!!!!

Always wear safety apparel when operating this equipment, safety glasses, ear protection, insulated waterproof gloves, and non-slip protective shoes are recommended. When using any cleaning chemicals refer to the chemical label for safety instructions concerning those chemicals for use of a respiration mask.

Never operate or let anyone operate this equipment while under the influence of any alcohol, drugs, or medication or when fatigued.

Pressure Washer

Definition of Pressure Washer: A machine that cleans dirty surfaces with high pressure water. This pressure washer produces cold water high pressure spray. Cleaning chemicals may be incorporated into the spray if desired on models equipped for "chemical induction through the pump". The Q2265 and Q2265E are clear water only. The pressure pump for this equipment is powered by a gasoline internal combustion engine.

WARNING: SPECIAL HAZARDS

- **CO Poisoning:** Exhaust from engine contains carbon monoxide, a poisonous gas that can cause carbon monoxide poisoning and possible death if inhaled.
- **Injection Injury:** High-pressure spray can pierce skin and underlying tissues, leading to serious injury and possible amputation. Such an injection injury can result in blood poisoning and/or severe tissue damage.
- **Flying Debris:** High-pressure spray can cause flying debris and possible surface damage.
- **Electric shock:** Operating equipment in wet conditions or near water can cause electric shock.
- **Chemical Exposure:** Cleaning chemical vapors or contact with skin may be hazardous.
- **Fire/Explosion:** Engine sparking can ignite fuel or other flammable liquids or vapors in the vicinity. Hot exhaust from engine can ignite combustible materials.
- **Burns:** Pressure Washer pump and engine are hot surfaces that can cause burn injuries. Detailed

Equipment Protection Facts

Inspect Upon Delivery: FIRST! Inspect for missing or damaged components. See "Initial Set-Up/Installation" section for where to report missing or damaged parts.

Add Engine Oil: Engine is shipped **without oil**. See the "Engine Manual" section of this manual for instructions on capacity and viscosity recommendations.

Water Flow Requirements: Make sure your supply water flow rate is 20% higher than the pressure washer's flow rate (see "Operations", section for detail), and that your water is clean and particle free.

Do not run Pressure Washer without proper inlet water supply to high pressure pump and for more than 1 minute without depressing trigger on gun to circulate water to avoid damaging pump.

Chemical Spraying: Use only approved pressure washer chemicals designed for high-pressure use. Use soap adjustment knob to regulate cleaning power (on select units).

Storage: Do not allow water to freeze in the pump, hose, or spray gun(s). See "Storage" for more information.

Maintenance Schedule: Engine and pump require periodic inspection and servicing to keep pressure washer functioning efficiently. See "Maintenance Schedule Summary" for frequency of servicing.

Battery: A battery is required for electric start feature (Denoted by **E in model # only**). A battery is not included. Purchase a standard 12VDC, 10 Ah battery, and further detail in "Specifications" section.

PLEASE READ THE FOLLOWING INSTRUCTIONS!

1. Unit Shipped without engine oil. Axial Cam Pump shipped with correct oil and sealed. See Pre-operating Instructions for further information.
2. For repair under Warranty or questions concerning Warranty, **DO NOT RETURN** this product to the Store where purchased. Follow the procedures as outlined in the "WARRANTY POLICY" and "WARRANTY REGISTRATION" in the Owner's Manual.
3. Read the "Owner's Manual" prior to operating any equipment and familiarize yourself with the proper and safe operation of the equipment.
- 4.

This Owner's Manual is for the Following Models:			
Q1325/Q1500	Q2265	Q2865	Q3370
	Q2265E		Q3370E

(E) Indicates unit is Electric Start Feature (Battery not included).

TABLE OF CONTENTS

Preface	6
Product Specifications	7
Safety Instructions	8
Controls and Features	11
PRE-OPERATING INSTRUCTIONS	12
Assembly	14
Engine Oil Level Check	17
Engine Fuel Level Check	18
Air Cleaner Element Check	19
Connecting Inlet/Outlet/Chemical Injection Hose	20
Battery Specifications	23
Operation of Pressure Washer	24
Transporting and Storing the Unit	28
Maintenance	29
Troubleshooting	34
Water Pump Safety	35
Safe Operations	36
Limited Warranty Policy	39
Electric Start Units	61

Preface

Thank you for choosing LIFAN for your Power Equipment needs. LIFAN prides itself on providing quality products at affordable pricing, creating the “Best Equipment Value on Today’s Market!”

Your High Pressure Washer utilizes our Industrial Grade Gasoline Engines combined with the premium grade Annovi Reverberi  High Pressure Pump to produce a high pressure water spray for cleaning purposes. Do not use this unit for other purposes as unforeseen hazards or equipment damage may result. This unit is intended for OUTDOOR USE ONLY.

All LIFAN products are manufactured utilizing the latest technology. Built with quality components, your new Power Equipment Product will give you years of dependable service. Your unit, along with all of LIFAN products are designed, engineered, and manufactured with LIFAN’s Industrial Grade Gasoline Engine.

This Owner’s Manual will provide you with all of your needed information for your new Power Equipment Product, including Safe Operation and Maintenance of your unit. Please keep and read this Owner’s Manual completely and carefully prior to operation. Keep this Owner’s Manual for assistance in the future, such as proper maintenance schedules and tips to prolong the life and effective use of your unit.

This Owner’s Manual contains information with respect to the newest products at the time of publication. Due to revision and modifications, the information noted in the Owner’s Manual might vary from the actual status. This Owner’s Manual is subject to change without notice.

PRODUCT SPECIFICATIONS

PRESSURE STORM PRESSURE WASHERS

Model Size	Q1325/Q1500	Q2265(E)	Q2865	Q3370(E)
Pump Manufacturer	Annovi Reverberi	Annovi Reverberi	Annovi Reverberi	Annovi Reverberi
Pump Type	RQV Axial Cam	RPV Axial Cam	RMV Axial Cam	RQV Axial Com
Pressure Output (psi ¹)	2100/1500 psi	2500psi	2800psi	3300psi
Delivery Output (gpm ²)	2 gpm	2 gpm	2.5gpm	3 gpm

ENGINE

Manufacturer	LIFAN	LIFAN	LIFAN	LIFAN
Model	LF152F-3Q	LF168-2FBQ	LF168F-2BQ	LF170F-BQ
Maximum Horsepower (MHP)	3mph	6.5mph	6.5mph	7mph
Engine Displacement	97cc	196cc	196cc	212cc
Starting System	Recoil	Recoil/Electric(E)	Recoil	Recoil/Electric (E)
Fuel Tank Capacity	0.37 Gallons	0.66Gallons	0.95 Gallons	0.95 Gallons
Engine Type	48Stroke OHV	48Stroke OHV	48Stroke OHV	48Stroke OHV
Fuel Type	87 Octane Gasoline	87 Octane Gasoline	87 Octane Gasoline	87 Octane Gasoline
Fuel Compliance	10% Ethanol or Less	10% Ethanol or Less	10% Ethanol or Less	10% Ethanol or Less
Oil Type & Amount	SAE10w30w 20oz	SAE10w30w 20oz	SAE10w30w 20oz	SAE10w30w 20oz
Low Oil Shutoff Protection	Yes	Yes	Yes	Yes
CARB Certified	(CA) Models Only	(CA)Models Only	(CA) Models Only	(CA) Models Only

DIMENSIONS

Length (inch)	16.5	28.2	27.0	27.0
Width (inch)	13.2	18.7	20.1	20.1
Height (inch)	19.3	22.5	17.7	17.7
Weight (lbs)				

ACCESSORIES

Adjustable Spray Lance	1 ea.	1 ea.	1 ea.
Gun	1 ea.	1 ea.	1 ea.
Inlet Hose	1 ea.	1 ea.	1 ea.
Outlet Hose	1 ea.	1 ea.	1 ea.
Chemical Injector	N/A	1 ea.	1 ea.
Adjustable spray Nozzle			
Wand & Hose Bracket	1 ea.	1ea.	1 ea.
Mobility/Wheel Kit		2 Wheels/T-bar	2 Wheels/bar handles

Comments

PSI¹ = Pounds per Square Inch

GPM² = Gallons per Minute

Safety Instructions



















This is the safety alert symbol. It is used to alert you to potential personal injury hazards. Obey all safety messages that follow this symbol to avoid possible injury or death.

For your safety read this manual carefully. Become familiar with the proper operation, care, and maintenance of your LIFAN PressureStorm Pressure Washer.

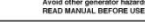
The safety and alert symbol () is used with a signal word (**CAUTION, DANGER, WARNING**), a pictorial and/or safety message to alert you to hazards. **CAUTION** indicates a hazard that, if not avoided, could result in minor or moderate injury. **DANGER** indicates a hazard that, if not avoided, could result in death or serious injury. **WARNING** indicates a hazard that, if not avoided, could result in death or serious injury.

Hazard Symbols and Meanings

					
EXPLOSION	FIRE	Electrical			
					
Toxic Fumes	Hot surface or gas	Kickback			

	WARNING!
<p>Running pressure washer emits carbon monoxide: an odorless, colorless, poison gas. Breathing carbon monoxide can cause nausea or death!</p>	
<p><i>ONLY operate pressure washers outdoors. Exhaust gas must be prevented from entering confined areas. Direct exhaust gas away from windows, doors, ventilation and other openings. Do not operate pressure washer inside or under any buildings.</i></p>	
	WARNING!

The Engine exhaust from this pressure washer contains chemicals known to the State of California to cause birth defects, reproductive harm and cancer.

Safety Instructions



WARNING!



Rapid recoil of starter cord (kickback) may pull hand and arm forward toward engine at a rapid rate.
Broken bones, bruises, sprains, and fractures may result.

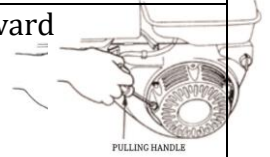

- When starting engine, pull cord slowly until tension is felt, then pull rapidly to avoid kickback.

WARNING!

Fuel and its vapors are extremely flammable and explosive.

Fire or explosion can cause severe burns or death.

WHEN ADDING OR DRAINING FUEL

- Turn pressure washer off and let it cool for at least three minutes before removing fuel cap. Loosen cap slowly in order to relieve pressure in the fuel tank.
- Fill or drain fuel tank outdoors. Do not excessively inhale fuel vapors.
- Keep away from open flames or sparks and other sources of ignition.
- Do NOT smoke while filling fuel tank.
- Do NOT overfill tank. Allow space for fuel expansion.

WHEN TRANSPORTING OR REPAIRING EQUIPMENT

- Transport pressure washer with the fuel valve in the off position.
- Repair pressure washer with the fuel tank empty or the fuel valve in the off position.
- Disconnect spark plug wire before transport or service.

WHEN STORING FUEL OR EQUIPMENT CONTAINING FUEL

- Store away from furnaces, stoves, water heaters, clothes dryers or other appliances that have pilot light or other ignition source because they can ignite fuel vapors.

WHEN STARTING EQUIPMENT

- Ensure spark plug, muffler, air cleaner, and fuel cap are in place.
- Do NOT crank engine with spark plug removed.
- If fuels spills, wait until it evaporates before starting engine.

WHEN OPERATING EQUIPMENT

- Do NOT choke carburetor to stop engine.
- Do NOT tip engine or equipment at an angle, which causes fuel to spill.

Safety Instructions



WARNING!

**While engine is running temperature may exceed 150°F (65°C).
Server burns may occur.**

Exhaust heat/gasses can ignite combustibles, structures or damage fuel tank causing a fire.

- Do NOT touch hot surfaces and do avoid exhaust gases.
- Allow pressure washer to cool before touching.
- Keep at least 7 ft. (183cm) clearance on all sides of pressure washer including overhead clear.
- Reflective exhaust heat may damage fuel tank causing fire.
- Code of Federal Regulation(CFR) Title 36 Parks, Forests, and Public Property require equipment powered by an internal combustion engine to have a spark arrester, maintained in working order, complying to USDA Forest service standard 5100-1c or later revision. In the state of California a spark arrester is required under section 4442 of the California Public resources code.

WARNING!

**Unintentional sparking can result in fire or electrical
shock.**



WHEN TESTING FOR ENGINE SPARK

- Do NOT check for spark with the spark plug removed.
- Use approved spark plug tester.

WHEN REPAIRING OR ADJUSTING WATER PUMP

- Disconnect the spark plug wire from the spark plug and place the wire where it cannot contact spark plug.

CAUTION!

Improper use and care of this pressure washer will cause damage and shorten its lifespan. Failure to follow these actions will void all warranties.

- Use pressure washer only for appropriate and designated purposes.
- Pressure washer must be placed on a level surface.
- Do NOT expose pressure washer to extreme conditions. Excessive dust, moisture, and corrosive vapors will damage unit.
- Cooling slots must be kept clear of debris.
- Shut off pressure washer and take to a qualified service center if the pressure washer fails to operate properly.

NOTE: NEVER ALLOW PRESSURIZED WATER EXITING SPRAY GUN TO CONTACT SKIN OF HUMAN OR ANIMAL.

Controls and Features

Electric Start Models Choke on Panel Inlet/Outlet Connections on Panel
Panel for Q1325/Q1500- Q2265/ Q2265E-Q2865 / Q3370 - Q3370E

1. **Spray Gun** – Lance and Gun screw together to form Spray Gun
2. **Outlet Hose** --- supplies pressurized water from pump to spray gun.
3. **Water Pump** – Annovi Reverberi  Direct Drive High Pressurized Water Pump.
4. **Frame** – One Inch steel tubing for maximum protection.
5. **Legs** – Support for Pressure Washer.
6. **Mobility Kit/Wheels** – Pneumatic Tires and Wheels for easy mobility.
7. **Fuel Cap** – Check/add fuel

Control Panel Features

Your Q1325/Q1500, Q2865, Q3370, and Q3370E are designed for convenient connections for the inlet and outlet hose connections on the panel and pre-plumbed from the back of the panel to the pump. With the on/off switch (Electric Start Switch on E models) and the Pull to Choke and Push to run panel mounted choke you have everything at your fingertips.

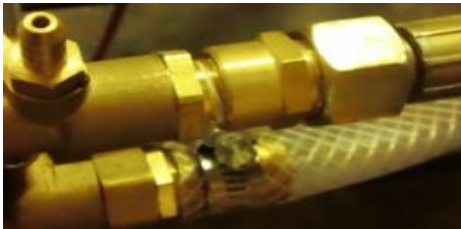

Key-on/off Switch Pull to Choke/Push to Run Inlet/Quick Connect Outlet Pre-Plumbed from High Pressure Pump to inlet/Outlet on Panel

Always check the inlet and outlet connections on the pump and back of panel for leaks or wear.

Pre-Operating Instructions: Assembly

Your LIFAN pressure washer is packaged without fuel and engine oil. Some assembly is required before operating your LIFAN Generator.

BOX CONTENT:

- Pressure Washer
- Accessory Kit
 - 1 ea. --- Spark Plug Removal Tool o 1 ea. – Outlet Hose
 - 1 ea. – Lance w/adjustable spray nozzle (Combines with Gun to form Spray Gun) o 1 ea. – Gun (Combines with Lance to form Spray Gun) o 1 ea. – Spray Gun & Hose Bracket
 - 1 ea. – Chemical Injector Hose except Q2565 and Q2565E

- Owner's Manual
- Warranty Registration Card
- Warranty Policy
- Wheel Kit
 - 2 ea. - Pneumatic Wide Tires and Wheels/Q2565(E) Low Profile solid 12"
 - 2 ea. - Rubber Support Leg
 - 1 ea. - Axle
 - 1 ea.- T-Bar Handle Q2865, Q3370 (E)

Hardware Bag

- | | |
|--------------------------|---------------------------------|
| 6 ea. – 12mm Bolt | 2 ea. – Handle Bolt (50mm Long) |
| 2 ea. – 3-Point Wing Nut | 2 ea. – 14mm Nut |
| 2 ea. – 18mm Nut | 2 ea. – Cotter Pin |
| 2 ea. – 1in Washer | |

Q2565 Q2565E

- | | |
|----------|------------------|
| 1, Frame | 4, Rubber stand |
| 2, Axle | 5, Wand assembly |
| 3, 12" | |

Pre-Operating Instructions: Assembly

UNPACKING THE GENERATOR:

1. Set the carton on a flat, rigid surface.
2. Remove all loose contents from carton EXCEPT the Engine/Pump/Bottom Frame portion of pressure washer and set them beside carton.
3. Open box completely by cutting each corner from top to bottom.
4. Leave Pressure Washer on the remainder of the box until Wheel Kit is installed. Never attempt to put oil in engine or operate the equipment until fully assembled.
5. Locate all box contents and place them beside the pressure washer. (Some Items may be packaged within the voids of the pressure washer itself.)

INSTALLATION:

The Following Tools are needed to assemble the Pressure Washer:

- Safety Glasses
- 8mm-14mm Wrench Set
- 8mm-14mm Ratchet & Socket Set
- 18mm Ratchet & Socket

HANDLE INSTALLATION: Q2565

Slide both ends of Handle into the two poles located behind the engine. The Handle should bend away from the water pump/engine.



Insert Handle Bolt through the holes of the handle and pole. Fasten with 3-point wing nut. The Wing Nut should be on the outside of the handle. The head of the Handle Bolt should fit flush against inside of handle.



Pre-Operating Instructions: Assembly

For electric Start models attach starter wire hanger to handle bolt per picture.



Handle Installation Q2865, Q3370 (E)

1. These units come with a T-Bar handle. The mount bracket to the frame is pre-drilled and threaded for the 4 bolts to attach the handle.



Handle in Down Position



Locking Pin



Locked in up position

2. Install the Axle with 2 Bolts and Nuts Pre-Drilled.



3. Install the Wide Pneumatic Wheels and Tires with Nyloc Locking Nut provided.



4. Install the wand, gun brackets and hose bracket in the pre-drilled holes with nuts and washers provided.



Top Wand Bracket



Bottom Wand Bracket



Hose Bracket

5. Battery Installation Electric Start Models. The Battery box is located on the frame rail.

Install Red (Hot) Lead to Positive Post and Black (Ground) to Negative Post pre wired to the electric starter on the engine.



Pre-Operating Instructions: Assembly

WHEEL KIT INSTALLATION: Wheels are installed under engine; Support feet are installed under pump end of base for Q 2130, Q 2565, for Q2865, Q3370, and Q3370E wheels are under pump and legs under engine.

NOTE: Install Wheel Kit BEFORE Filling the Pressure Washer with Fuel or Oil. Never Tip a Unit that contains Fuel or Oil.

1. Carefully tip pressure washer so the Handle is touching the ground and the pump is facing the sky. For **Q2865** and **Q3370** the Handle End should be facing the sky and the pump end the ground.
2. Using two 12mm Bolts, attach one Heavy-Duty Rubber Leg to the base of pressure washer. Securely



tighten using 12mm Ratchet and Socket or like tools.

3. Repeat Step 5 to attach the second Heavy-Duty Support Leg.
4. Carefully tip the pressure washer so the back of the handle is facing the sky and the pump is facing the ground. For **Q2865** and **Q3370** the pump end will be facing the sky, the handle end down.
5. Using two 12mm Bolts, attach Axle. Securely tighten using 12mm Ratchet and Socket or like tools.



6. Slide 1in. Washer onto each end of the Axle.
7. Slide Wheel onto each end of the Axle.
8. Securely tighten 18mm Nut to each Axle using 18mm Ratchet and Socket or like tools. For **Q2865** and



Q3370 use included Nyloc wheel nut retainers

9. Slide Cotter Pin through hole on each end of Axle. Bend the ends of the Cotter Pin to ensure the Cotter Pin will not slip out.
10. Carefully stand the pressure washer up with the wheels and support legs touching the ground.

Pre-Operating Instructions: Assembly

ADDITIONAL INSTALLATION:

1. Slide the Spray Gun & Hose Bracket through the holes on the Handle. Securely tighten using the 14mm nuts and a 14mm Ratchet and Socket or like tools.



2. Screw the Lance w/adjustable spray nozzle and Gun together to form Spray Gun. (Refer to picture below.)
3. Place Spray Gun on the Spray Gun & Hose Bracket.



Gun



Assembled Gun and Wand w/Adjustable Hose
Spray Nozzle Hi-Pressure



Hose

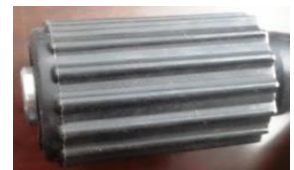

Connection Pump - Gun

Pre-Operating Instructions: Engine Oil Level Check

CAUTION:

- Running engine with insufficient engine oil can cause severe damage to the engine.
- The engine performance and service life is directly dependent of the quality of the engine oil. Do NOT use contaminated engine oil or vegetable oil.
- Check engine oil level only with engine stalled and with unit on level ground.
- Use 4-Stroke Gasoline Engine Oil equivalent in quality with SF, SG from API.

Oil viscosity varies with average environmental temperature. Select engine oil with proper viscosity using the chart to the right in accordance with your regional environmental temperature.

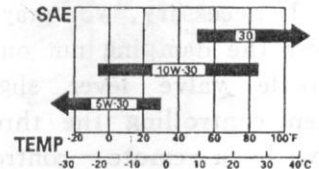

Fig. 5

Engine Oil Alarm System

The engine oil alarm system aids in avoiding engine damage due to improper amounts of engine oil in the crankcase. Before the engine oil level in the crankcase drops below the safety line, the engine oil alarm system will automatically stall the engine (while the engine switch remains in the "ON" position).

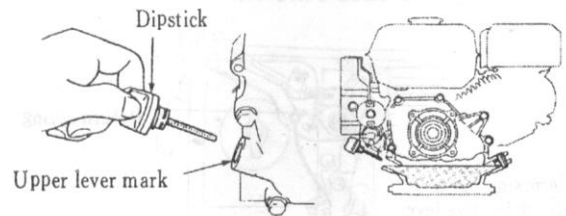
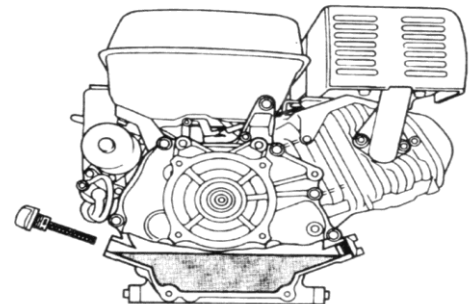

Fig. 6

If the engine stops and will not restart:

1. Remove the engine oil dipstick and wipe it clean.
2. Insert the dipstick into engine oil filler hole without screwing it in
3. Remove dipstick and check engine oil amount.
4. If engine oil is below required amount, fill specified engine oil up to the top of filler hole. Use engine oil depended on environmental temperature.
5. Reinstall the engine oil dipstick.



Pre-Operating Instructions: Engine Fuel Level Check



CAUTION:

- Gasoline is extremely flammable. Keep away from ignition sources.
- Fuel unit only in well-ventilated areas with the engine stalled.
- Do NOT smoke near unit.
- Do NOT spill fuel out of the fuel tank. Spilled gasoline and gasoline vapor may ignite. If gasoline is spilled, wipe completely dry before starting the engine.
- Avoid repeated or sustained breathing of gasoline fumes.
- Avoid skin contact with gasoline.
- Keep out of reach of children and pets.
- Do NOT use contaminated gasoline. Keep dirt, dust, and water out of fuel tank.
- After fueling is complete, ensure fuel filler cap is securely fastened.
-

TO CHECK ENGINE FUEL LEVEL:

1. Remove fuel filler cap.
2. Visually check fuel level within gas tank.
3. If too low, add fuel. Do NOT fill above the shoulder of the fuel strainer. Use only unleaded automotive gasoline with an Octane level of 87 or higher.

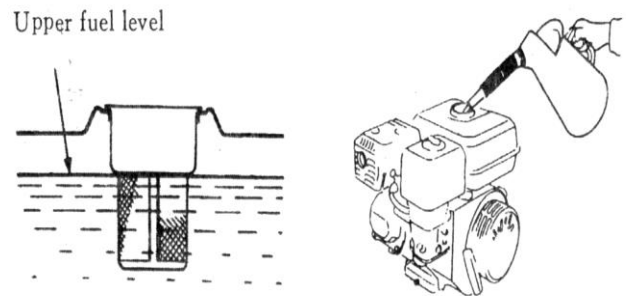

Fig. 12

BLENDED FUELS

Gasoline is sometimes blended with alcohol or an ether compound to increase the octane level. If blended fuels are used, ensure the octane rating is at least equal to the recommended octane level in the product specifications. The following three blended fuels recommended:

- **Ethanol (ethyl or grain alcohol)** – Gasoline containing 10% ethanol by volume.
- **MTBE (methyl tertiary butyl ether)** – Gasoline containing no more than 10% MTBE by volume.
- **Methanol (methyl or wood alcohol)** – Gasoline containing no more than 5% methanol by volume.
-

NOTE: *Damage caused by the use of blended fuels is NOT covered under warranty.*

Pre-Operating Instructions: Air Cleaner Element Check



CAUTION:

- Do NOT run the engine without air cleaner element installed. Operation of engine without air cleaner element installed will result in the inhalation of dirt, dust, and other debris into the engine and through the carburetor. This will result in premature wear of the engine.

To Check Air Cleaner Element:

1. Remove the wing-nut from the top of the air filter housing and remove top.
2. Remove the wing nut from the air filter and check for debris or stoppage. If dirty replace with the correct Air Filter for your unit. They are available at your dealer or from LIFAN Power USA. Order your filter by calling toll free 866-471-7464.
3. Re-Install the air filter element into the air filters housing and re-attaché the air box top, tighten wing nut to firm.

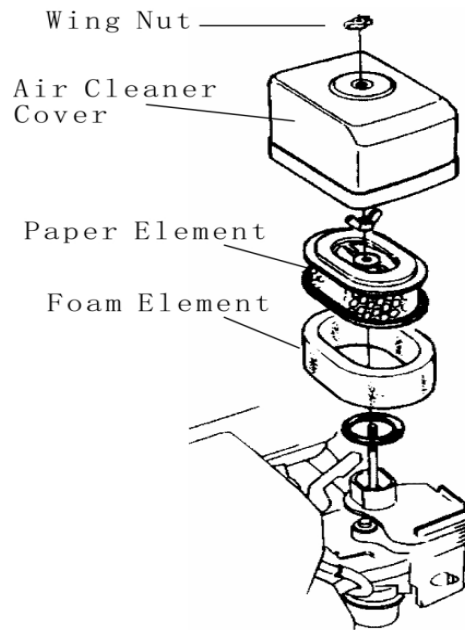

Pre-Operating Instructions: Connecting Inlet/Outlet/Chemical Injector Hose



CAUTION:

- Use only provided hoses or replacement hoses equal in quality. Use of improper hoses may result in injury. Check hose for worn spots or leaks.

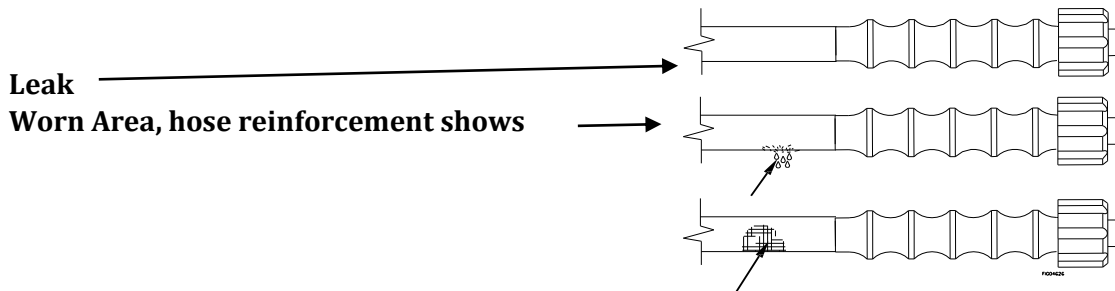

- Use of chemical hose required only if cleaning agents are applied during washing. Adjustable spray wand must be adjusted to least pressure to siphon chemicals.
- Ensure each hose connection is tightly secured. Failure to do so may result in injury or damage to the unit.
-

Chemical Injector Connection

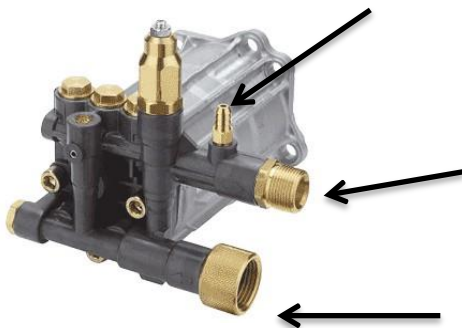

Outlet Hose Connection

Inlet Hose Connection

Pre-Operating Instructions: Connecting Inlet/Outlet/Chemical Injector Hose

CONNECTING INLET HOSE:

1. Connect Inlet Hose to Inlet Hose Connection on Pump or on panel. Tighten Securely.
 2. Connect alternate end of Inlet Hose to a water tap. The water tap must deliver at least 20psi (pounds per square inch).
 3. An insufficient water supply will damage your pump. Make sure the water supply is steady and is 20% over the rated flow of your pump
- NOTE: Under NO circumstance should the pressure washer be used as a self-prime from a water vessel.

CONNECTING OUTLET HOSE: Outlet Hose must be a High Pressure Hose. NOTE: The Outlet Hose (High Pressure Hose) provided is the BLACK Hose. The outlet or high pressure hose must be checked for any wear or leakage. Replace any damaged high pressure hoses.

1. Connect the Outlet Hose to Outlet Hose Connection on Pump or on panel. Tighten Securely.
2. Connect alternate end of Outlet Hose to Spray Gun as shown below. Tighten Securely



Pre-Operating Instructions: Connecting Inlet/Outlet/Chemical Injector Hose

CONNECTING CHEMICAL INJECTOR HOSE: Water to Chemical ratio is 7:1. NOTE: The Chemical Injector Hose provided is the white/clear hose and should be used in unison with the Spray (black) Nozzle.



CAUTION: WHEN USING CHEMICALS OR CLEANING SOLUTIONS:

- Use low pressure setting only for chemicals.
 - Use **ONLY** soaps and chemicals designed for pressure washer use.
 - Do **NOT** use bleach.
 - Ensure water to chemical ratio is 7:1.
 - Ensure chemicals are **NOT** allowed to remain in pump after use. Failure to clean chemicals out of pump will damage unit and void warranty.
1. Connect the Chemical Injector Hose to the Chemical Injector Connection on Pump. Tighten Securely.
 2. Place alternate end of Chemical Injector Hose into chemical/cleaning solution to be used. This end of the Chemical Injector Hose will have a filter to keep foreign debris from entering pump.
 3. After use of Chemicals/Cleaning Solutions, place the end with the filter of the Chemical Injector Hose in clean water and allow to operate for three (3) minutes to clean excess chemicals from pump housing.
 - 4.

NOTE: *Chemicals will NOT siphon while Spray Wand is in High-Pressure settings.*

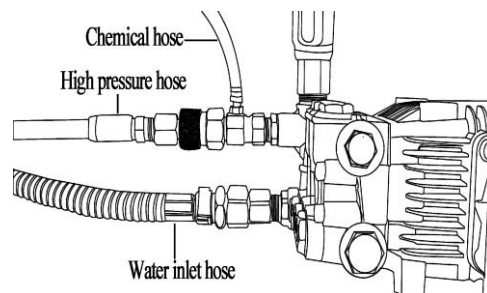

Pre-Operating Instructions: Battery Specifications

(Electric Start (E) Models Only)

The Battery is NOT included with your Energy Storm Generator. These units require an Acid Cell Battery. This battery is used in many applications, such as lawnmowers, ATV's, motorcycles, etc. and can be found at many retailers and dealers including where you purchased this Power Equipment Product. Use the "Battery Specifications" chart below to attain the specifications of the necessary battery. Or, use the "Cross Reference Models" chart below to match up with the manufacturer's model number with the brand battery available at your local retailer.

BATTERY SPECIFICATIONS				
Generator Model	Length (inch)	Width (inch)	Amp (hrs)	DC Voltage (Volts)
Q2565	5.25 in	3 in	10	12V
Q2865	5.3125 in	3.1875 in	12	12V
Q3370	5.3125 in	3.1875 in	12	12V

CROSS REFERENCE MODELS		
Generator Model	Manufacturer	Model Number
Q2565	Super Start®	CB9B
Q2865	Excide®	12N12A-4A-1
Q3370	Excide®	12N12A-4A-1

Note: (-CA) or (E) Models have same Battery Specifications

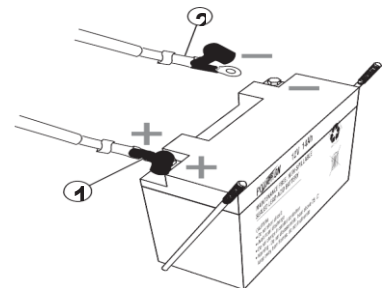

	<h2>Warning</h2>
Follow all the battery manufacturers' warnings for proper installing of your battery in order to prevent damage to personnel or equipment.	



1. Battery leads consist of a Red (hot) lead that connects to the (+) battery post and is connected to the (+) terminal on the starter solenoid and a Black lead which is connected to the (-) negative battery terminal and the frame mounting bolt.
2. Connect the Red (hot) terminal to the battery.
3. Connect the Black (negative) terminal to the battery.

Operation of Pressure Washer

Pressure Washer Use Location:

WARNING!	
	Running pressure washer gives off carbon monoxide gas. It is odorless, colorless, and highly toxic. Breathing carbon monoxide gas can lead to fainting, nausea or may result in death.
	
<ul style="list-style-type: none">• Only operate pressure washer outdoors.• Prevent exhaust gas from entering, through windows doors or ventilation intakes, any confined areas.• DO NOT operate pressure washer inside any enclosed or roofed areas.	

BEFORE OPERATING PRESSURE WASHER: Refer to Pre-Operating Instruction section for additional procedures and definitions.

1. Check pressure washer condition.
 - a. Inspect for signs of damage, oil or fuel leaks.
 - b. Remove excessive dirt and/or debris from the unit.
2. Check Inlet, Outlet, and Chemical Injection Hoses.
 - a. Inspect general condition of hoses to ensure hoses are in serviceable condition.
 - i. Outlet Hose must be constructed to withstand High-Pressure.
 - b. Ensure hoses and nozzles are securely installed.
3. Check the Engine.
 - a. Ensure proper engine oil amount.
 - b. Ensure air cleaner element is clean and installed.
 - c. Ensure proper fuel level amount.
4. Ensure pressure washer is on a level surface.
5. Ensure engine switch is in the "OFF" position.
6. Ensure pressure washer is at least 7ft away from building walls and other equipment during operation. Do NOT place flammable objects close to pressure washer.
7. Always operate within the length of your water hose for inlet pressure.
8. Do not operate with any tarps, covers, and any objects on top of the unit.
9. Exhaust gas is hot and can cause combustible materials around your unit to ignite, make sure unit is not operated within 7 feet of any combustible materials and always keep a properly charged fire extinguisher and be familiar with the use of the fire extinguisher.

Operation of Pressure Washer

STARTING THE ENGINE:

Do not run Pressure Washer without proper inlet water supply to high pressure pump and for more than 1 minute without depressing trigger on gun to circulate water to avoid damaging pump.

Refer to the Controls and Features section for additional diagrams and definitions.

1. Depress the Spray Gun trigger.
2. Move the fuel cock to the "ON" position.
3. To start a cold engine, place the choke lever in the "OFF" position. For LEVER mounted choke pull to choke. To restart a warm engine, leave the choke level in the "ON" position. For panel mounted choke models push to run or to start a warm engine.
4. Move the throttle valve lever away from the "LOWER" position, about 1/3 of the way toward the "UPPER" position.
5. Place the throttle lever halfway between the "UPPER" and "LOWER" settings.
6. Place the engine switch to the "ON" position.
7. Pull the recoil starting handle lightly until resistance is felt, then pull briskly. Do NOT allow the starter handle to snap back against the engine. Return it gently to prevent damage to the starter.
8. For electric start models, equipped with a key switch turn the switch to the ON position, for models with the rocker switch start, push the rocker switch to the ON position. Hold the key in the start position or the rocker arm in start position until the engine starts or for no more than 10 engine rotations. If the engine does NOT start, wait 15 seconds and repeat starting procedures.
9. After starting the engine, move the throttle lever to the "UPPER" position for self-priming.

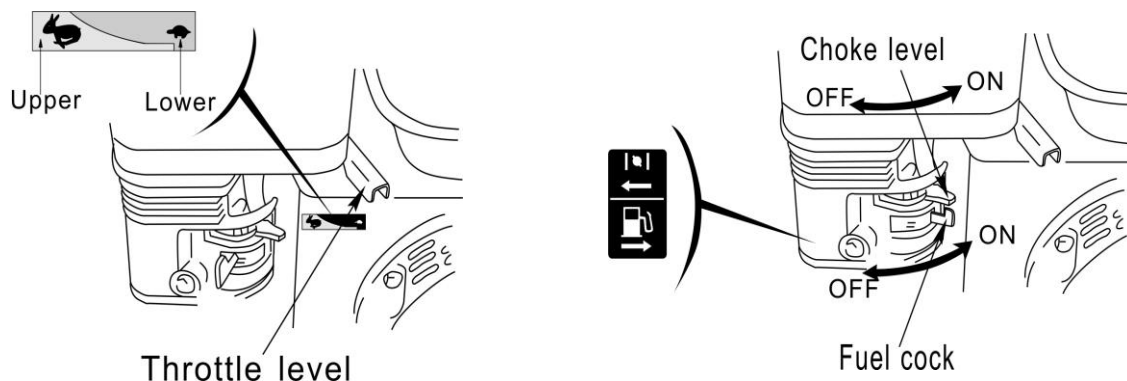

Operation of Pressure Washer

PRESSURE WASHER OPERATION:

CAUTION:

- Avoid contact of high-pressure water exiting spray gun with humans or animals. See "Rules for Safe Operation" for medical information.
- Use proper pressure setting to avoid damage of cleaning surface.
- Point tip of spray gun toward cleaning surface and depress trigger.

Do not run Pressure Washer without proper inlet water supply to high pressure pump and for more than 1 minute without depressing trigger on gun to circulate water to avoid damaging pump.

ADJUSTING PRESSURE OUTPUT: The pressure setting is preset at time of manufacturing to provide optimum pressure and cleaning.

TO LOWER PRESSURE:

- Increase the distance between the Spray Gun and the surface being cleaned.
- Reduce the speed of the engine by moving the throttle lever toward the "LOWER" setting.
- Adjust the adjustable spray tip to a wider water fan and less pressure.
- Adjust the Pressure Regulator Knob on the pump. Turn counterclockwise to lower pressure output. After use, return the Pressure Regulator Knob to its original position.

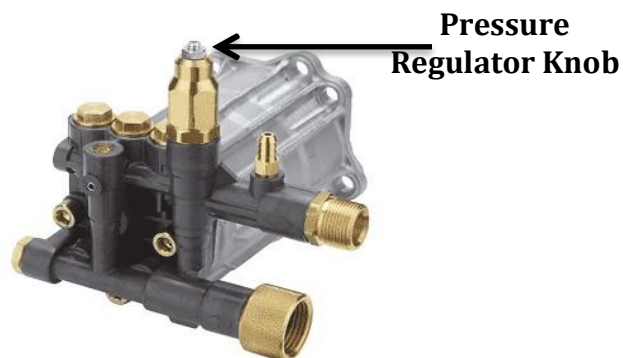

Operation of Pressure Washer

STOPPING THE ENGINE:

Refer to the Controls and Features section for additional diagrams and definitions.

IN EMERGENCY:

- 1. Turn the engine switch to the "OFF" position.**
- 2. Turn the inlet water supply to the "OFF" position.**
- 3. Depress gun trigger to expel remaining pressurized water.**

NORMAL PROCEDURE:

1. If the chemical injection hose was used with chemicals, allow pressure washer to operate for three (3) minutes while in-taking clean water through chemical injection hose.
2. Move the throttle valve lever to the "LOWER" position.
3. Turn the engine switch to the "OFF" position.
4. Turn the fuel cock to the "OFF" position.
5. Depress the spray gun trigger.

Transporting and Storing the Unit

CAUTION:

- To avoid fire, allow unit to cool down for at least twenty (20) minutes before transporting or storing the unit.
- Always transport and store the unit with the fuel cock in the “OFF” position.
- Always keep unit in horizontal position to the ground to prevent fuel from spilling. Spilled gasoline and gasoline vapor may ignite.
- Gasoline is extremely flammable and explosive.

STORING THE PRESSURE WASHER: Refer to the Controls and Features section for additional diagrams and definitions.

1. Ensure the storage site for the unit is clean and dry.

Before long term storage of your power equipment product, typically 30 days or more, perform the following:

2. Set the fuel cock (valve) to the “OFF” position.
3. Let the unit continue to run until it stops itself, burning all of the fuel in the fuel system. Keep inlet water supply to pump and continue to use the spray wand with the trigger depressed to keep water circulating in the pump and to expel pressurized water.
4. Turn the ignition switch to the “OFF” position.
5. Drain the engine oil in accordance with the “Engine Oil Change Procedures” in this Owner’s Manual’s Maintenance section. Do NOT re-fill with oil until ready to use again.
6. Remove the Spark Plug in accordance with the “Spark Plug Maintenance” in the Owner’s Manual’s Maintenance section. Spray a lubricant, such as WD40®, into the Spark Plug hole to lubricate the top of the piston and walls of the cylinder. Replace the Spark Plug.
7. Pull starter rope until resistance is felt. This will place the valves in the closed position.
8. Add the recommended amount of fuel stabilizer, in accordance with the amount recommended by the manufacturer of the fuel stabilizer, to the unused gasoline left in the unit’s tank.
9. Place the unit in a clean, dry, and secure location.
10. Cover the unit to protect from dust.
11. If stored in freezing conditions you can utilize a short garden hose and a funnel to install anti-freeze into the inlet connection on the pump.

Maintenance

MAINTENANCE SCHEDULE	
PROCEDURE	TIME
Engine Oil Check	Each Use
Replace Engine Oil	After Each 40 Hours of Use (For Initial Break in – After First (1 ST 10 Hours of Use
Air Cleaner Filter	Check Each Use/Replace As Needed or After Every 100 Hours of Use
Impeller Check	After 300 Hours of Use or After First Year
Air Cleaner Wash	When Needed or Max 50 hrs run time
Spark Plug	When Needed or Max 100 hrs run time
Valve Clearance	Check & Re-adjust annually or after 300 Hours of Use
Fuel Tank	Replace Every 3 Years Based on Condition

NOTE: Refer to Following Procedures for Proper Method to Perform Maintenance

Maintenance

ENGINE OIL CHANGE PROCEDURES: Do not run without proper water supply to high pressure pump to avoid damaging pump.

Periodic Maintenance of your engine oil should be performed after each 40 hours of use of you Power Equipment Product. Check your engine oil level prior to each use.

1. Start your engine and let it warm up to get the oil warm and thinner. After warm up turn engine off. Be sure during warm up sufficient inlet water is supplied to unit and gun trigger is depressed to avoid damage to the pump. Remove the dipstick (Refer to Controls and Features section) by turning counter clockwise. Remove the oil drain plug (Refer to Controls and Features section) located below the dipstick utilizing the appropriate tools. During warm up on pressure washer always supply inlet water and depress spray gun to circulate water in pump to avoid damage to pump.

CAUTION: THE OIL MAY BE HOT

2. Drain the engine oil into an approved receptacle and discard in accordance with all Federal and State Regulations. Never dump your used engine oil on the ground or into drains, only discard in an approved manner. Check with your local authorities to determine the regulations in your area.

WARNING! AVOID SPLASHING OF HOT OIL; IT CAN BURN YOU AND CAUSE SEVERE INJURY.

3. After oil is completely drained, replace oil drain plug and tighten with appropriate tools. Replace oil with the proper oil for your product. Refer to the Pre-Operating Instructions: Engine Oil Level Check section for exact fill requirements. Always use your dipstick to check the oil level and only fill to the full mark on the dipstick. Never overfill the engine, as this can cause damage to the unit and void warranty.
4. Replace the dipstick on your engine.

PROPER MAINTENANCE OF YOUR UNIT WILL INCREASE THE LIFE OF YOUR PRODUCT. THE OIL MUST BE CHANGED ON A REGULAR BASIS FOR PROPER OPERATION, AND RELIABILITY AND TO ALSO MAINTAIN YOUR WARRANTY ON THIS PRODUCT.

Maintenance

AIR CLEANER MAINTENANCE:

1. Remove the clip (item 9 in “Air Cleaner A” below) or the wing nut (item 7 in “Air Cleaner B” below) to remove and check the air filter element.
2. For Sponge Type Air Filters, wash with soap and water when contaminated. Squeeze excess liquid from air filter element, and allow the air filter element to dry.
For Paper Type Air Filters, replace with the correct Air Filter for your unit. They are available at your dealer or from LIFAN Power USA. Order your filter by calling toll free 866-471-7464.
3. Re-Install the air filter element into the air filters housing.

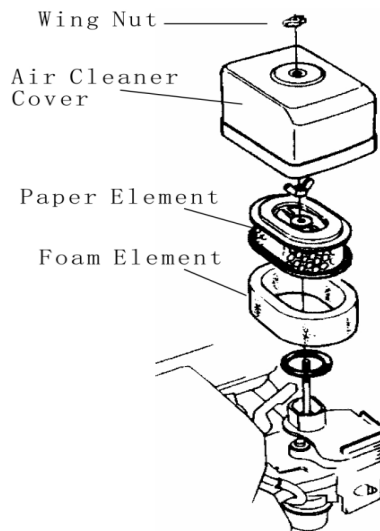

Air Cleaner and Filter Cartridge (Call Lifan Power USA for replacement air filter cartridge's or visit your retailer)

Maintenance

SPARK PLUG MAINTENANCE:

1. Remove Spark Plug Cap.
2. Remove Spark Plug with socket and handle supplied with your unit.
3. Clean any carbon build-up around the Spark Plug.
4. Check the Spark Plug Gap and adjust if necessary. 0.028-0.031inch gap.
5. Lubricate the threads of the spark plug with anti-seize compound or engine oil.
6. Re-install the Spark Plug and Spark Plug Cap.

Spark Plug
Removal Tool

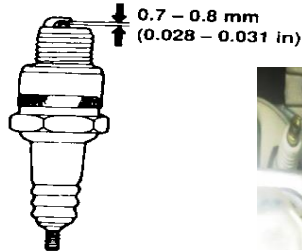
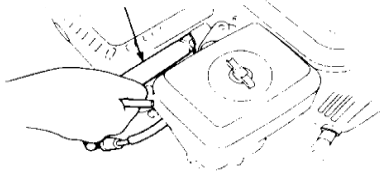

FUEL SYSTEM MAINTENANCE:

NOTE: Periodically you can get sediment or trash in your Carburetor Bowl. Use the following procedures to clean:

1. Turn the fuel cock (valve) to the "OFF" Position.
 2. Remove the carburetor bowl by removing the mounting bolt located at the bottom of the bowl.
 3. Dump out the old fuel and sediment into an approved container
 4. Clean carburetor bowl thoroughly.
 5. Fit a new rubber washer into place and re-attach fuel bowl to the carburetor. **NOTE: Removal of the drain screw at the bottom of the bowl can drain the fuel to remove smaller debris that has collected in the bowl.**
 6. After bowl is securely back in place, turn the fuel cock to the "ON" position for use.
- Units equipped with a pre-filter for fuel will have a filter housed just below the fuel cock. Remove the fuel filter element and clean or replace the fuel filter element (diagram below).



Fuel Filter Element Removal



Fuel Filter Element Assembly

Maintenance

Muffler Maintenance: Every 50 hrs of operation remove the "Spark Arrestor" per the diagram below and clean or replace.

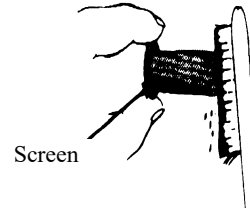
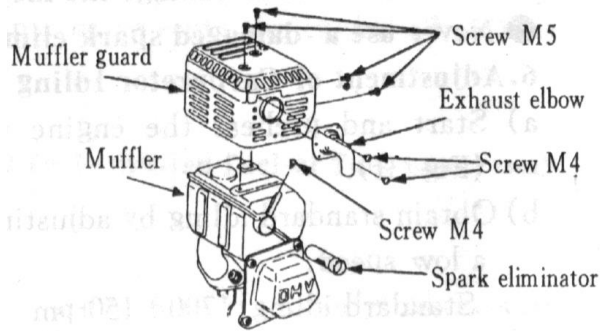

ANNOVI REVERBERI AXIAL CAM PUMP:

Unit undergoes extensive testing at the time of manufacturing. Lifetime oil is installed in pump and pump is sealed. Pump oil will NOT have to be checked or changed. Pump under warranty by manufacturer. Refer to Warranty Policy for details.

Do not run Pressure Washer without proper inlet water supply to high pressure pump and for more than 1 minute without depressing trigger on gun to circulate water to avoid damaging pump.

USAGE IN HIGH ALTITUDE REGIONS:

In regions with high altitude, the standard carburetor produces overly dense combinations of fuel and air, which result in decreased engine performance and increased fuel consumption. To maintain high engine performance at high altitudes, install a high altitude carburetor main spray nozzle and re-adjust the adjusting screw for idle speed. For usage in regions with an altitude of over 4,527ft (1380m), contact your dealer to replace the standard carburetor and make needed adjustments in advance. Even with a proper high altitude carburetor spray nozzle installed in the engine, the power output of the engine will drop about 3.5% with every 1000ft (305m) increase in altitude. If the standard carburetor jets are not replaced and adjusted for usage in high altitude, the increased altitude effect will be even more severe.

NOTE: Usage of the water pump in regions with lower altitude than the high altitude carburetor spray nozzle is applicable, may result in decrease of engine performance. The engine may become overheated and over-lean combination of fuel and air produced, may cause severe damage to the engine.

Troubleshooting

IF THE ENGINE WILL NOT START:

1. Check to ensure switches are in the “ON” position.
2. Check engine oil level. The unit possesses a Low Oil Shutdown feature that will not allow your engine to start if the oil is below safe operating levels. This feature is installed to increase the life of your engine and prevent engine damage. If oil level is low, fill to the full mark on dipstick. Refer to the Pre-Operating Instructions: Engine Oil Check section for exact oil type and amounts.
3. Check the fuel level to insure adequate fuel. Add fuel if necessary.
4. Remove and inspect the spark plug for cleanliness and proper electrode gap. If needed, clean or replace the spark plug. Refer to Spark Plug Maintenance in the Maintenance section of the Owner’s Manual for proper procedure.
5. If the unit will still NOT start after performing the above checks, call our customer hotline at LIFAN Power USA Toll Free 1-866-471-7464 or take the unit to an authorized Service Center.

NOTE: Periodically on the initial start-up or after the unit has been stored for a long period of time, the float for your “Low Oil Shutdown” system will stick to the bottom of the oil pan. Locate the two (2) wires to the Low Oil Sensor Diode (figure “Low Oil Sensor Diode” to the right) located on the side of the engine block. Unplug these wires and, **only after ensuring the engine is full of oil**, start the engine and allow to run until warm (normally 20 minutes, as this will heat the oil and release the float on the Low Oil Shutdown System). Then re-plug the wires to the terminals on the Low Oil Shutdown Sending Unit.



IF WATER IS LEAKING:

- Ensure Outlet Hose is securely tightened.
- Ensure Inlet Hose nut is securely tightened.
- Call dealer for repair if pump housing is leaking.

IF ABNORMAL NOISE FROM PUMP HOUSING:

- No water inside pump – Ensure Inlet Hose is connected and supplying recommended supply of water to pump. Check to see if the inlet hose is kinked.

IF NO WATER EXITING FROM SPRAY WAND:

- Ensure Inlet Hose is NOT clogged or kinked.

Pressure Washer Safety

1. *Never operate a gasoline engine powered product in any enclosed spaces, as they produce deadly Carbon Monoxide Poisonous Gases.*
2. Do NOT operate your power equipment in inclement weather such as rain, snow, and/or sleet.
3. Do NOT operate your power equipment within seven (7) feet of any flammable materials.
4. When refueling your power equipment never smoke or refuel near any flame or ignition devices. Never refuel while the unit is running. If during the refueling process some fuel is spilled, always completely clean the fuel and allow sufficient drying time prior to re-starting your unit. Gasoline vapors ignite easily and are very dangerous.
5. **NEVER ALLOW CHILDREN OR ANIMALS TO BE NEAR THIS EQUIPMENT DURING OPERATION. ONLY QUALIFIED PERSONS SHOULD OPERATE THIS EQUIPMENT. PLEASE FOLLOW ALL GUIDELINES CONTAINED IN THIS OWNER'S MANUAL FOR THE SAFE OPERATION OF THIS EQUIPMENT.**

Safe Operation

Follow Safety Rules for Operation

After you have checked and fueled the equipment and positioned it in a suitable worksite, it is time to start your pressure washer. The following are the procedures necessary for safe, successful operation of your pressure washer.

WARNING

Failure to follow safety rules may result in serious injury or death to the operator or bystanders.

Instruct operators. Owner must instruct all operators in safe set-up and operation. Do not allow anyone to operate the pressure washer who has not read the Owner's Manual and been instructed on safe use practices.

Safety equipment/controls. Always operate with all safety covers, guards, and barriers in place and in good working order, and all controls properly adjusted for safe operation.

Moving parts. Keep hands, feet, hair and apparel away from moving parts. Air vents may cover moving parts and should be avoided as well. Never remove any guards while the unit is operating.

Ear Protection. Hearing can be damaged from prolonged, close-range exposure to the type of noise produced by this pressure washer. The use of ear plugs or other hearing protection device is recommended for persons working within 15-20 feet of the running pressure washer for an extended period of time.

Eye Protection. Wear ANSI/OSHA required "Z87.1" safety glasses when operating or servicing the pressure washer. Pressurized spray from this unit can cause severe injury to the eyes. Small objects can become airborne as the spray contacts them

NOTE!

Before starting the pressure washer, review the following general safety rules for operation:

Conditions for Use

Know how to stop. Be thoroughly familiar with proper use of the equipment and all controls and connections. Know how to stop the pressure washer and depressurize system quickly if needed.

Instruct all operators. The pressure washer's owner must instruct all operators and potential renters in safe set-up and operation. Do not allow anyone to operate the pressure washer who has not read the Owner's Manual and been instructed on its safe use.

Safe Operation

Adult control only. Only trained adults should setup and operate the pressure washer. Do not let children operate. Pressure washers can generate forces greater than children can control and require judgment beyond what can be expected of children.

Under the influence. Never operate, or let anyone else operate, the pressure washer while fatigued or under the influence of alcohol, drugs, or medication.

Safety equipment / controls in place. Do not operate the pressure washer unless all safety covers, guards, and barriers are in place and in good working order, and all controls are properly adjusted for safe operation.

Damaged. Do not operate the pressure washer with damaged, missing, or broken parts. Never attempt to repair a high pressure hose or component. Always replace it with a part that is rated at or above the pressure rating of the machine.

Modifications. Do not modify the pressure washer in any way or deactivate any safety device. Do not change or add to fuel tank, fuel lines, or exhaust system.

Modifications can result in hazards related to carbon monoxide poisoning, fuel leaks, fire, explosion or other serious safety hazards, and will also void the warranty.

During Use

Stay alert. Watch what you are doing at all times.

Clear work area Clear the work area of all bystanders.

Keep children and pets away.

Keep spray away from electrical wiring. Spray contact with electrical wiring will likely result in severe electrical shock or electrocution.

Hot exhaust/parts Stay clear of engine exhaust. Never touch hot engine muffler, or other hot surfaces. All are very hot and will burn you.

Never pull by hose. Do not move this machine by pulling on the hose. Hose or connections could fail and result in catastrophic high pressure release of fluid as well as hose whipping.

Avoid sharp objects. Keep hose away from sharp objects. Bursting hoses may cause injury.

No load bearing. Do not use the pump to support other items of equipment that impose unacceptable loads on the pump. Do not attempt to use this machine as a prop.

Lock trigger safety latch when not spraying. Spray gun is equipped with a built-in trigger safety latch to guard against accidental trigger release. Rotate safety latch to the locked position when not spraying.

Do not run Pressure Washer without proper inlet water supply to high pressure pump and for more than 1 minute without depressing trigger on gun to circulate water to avoid damaging pump.

Safe Operation

Leaving unattended Always turn off the pressure washer and relieve system pressure before leaving the sprayer unattended

Prompt Emergency Response

Seek medical aid for suspected injection injury. If injured by high-pressure fluid, no matter how small the wound is, see a doctor at once. A typical injection injury may be a small puncture wound that does not look serious. However, severe infection or reaction can result if proper medical treatment is not administered immediately by a doctor who is familiar with injection injuries.

Seek medical aid for suspected carbon monoxide poisoning. The running engine gives off carbon monoxide, a poisonous gas that can kill you. If you start to feel sick, dizzy, or weak while using the pressure washer, shut off the engine and get to fresh air RIGHT AWAY. See a doctor. You may have carbon monoxide poisoning.

Put on Personal Protective Gear

 WARNING: Personal Protective Gear
Use personal protective gear to prevent:
- Eye and skin injection injury from high pressure spray
- Eye injury from flying debris

1. Wear waterproof gloves, safety glasses with side and top protection, face protection, and protective clothing when operating the machine. If spraying pressure washer specific chemicals, wear a respirator mask to avoid inhalation of vapors if directed on the chemical label.
2. Wear non-slip, protective footwear. Use of pressure washer can create puddles and slippery surfaces. Wear footwear capable of maintaining a good grip on wet surfaces.
3. Wear footwear capable of maintaining a good grip on wet surfaces.

LIMITED WARRANTY POLICY

EXCLUSIONS

- Costs of normal maintenance and adjustments.
- Failures caused by any contaminated fuels, oils, or lack of proper oil levels.
- Repairs or diagnostics performed by individuals other than Lifan authorized dealers not authorized in writing by Lifan.
- Failures due to normal wear and tear, accident, misuse, abuse, negligence or improper use.
- As with all mechanical devices, the Lifan engines need periodic part(s) service and replacement to perform as designed. This warranty will not cover repair when normal use has exhausted the life of a part(s) or engine.
- Failures caused by any external cause or act of God, including but not limited to, collision, theft, vandalism, riot, war, fire, freezing, lightning, earth-quake, windstorm, hail, water, flood, tornado, or hurricane or any occurrence outside of normal use and activity .
- Damage related to any animal infestation to include rodent and/or insect infestation.
- Products that are modified or altered in a manner not authorized in writing by Lifan.
- Any incidental, consequential or indirect damages caused by defects in materials or workmanship, or any delay in repair or replacement of the defective part(s).
- Failure due to misapplication.
- Telephone, cellular phone, facsimile, internet access, or other communication expenses.
- Expenses related to “customer instruction” or troubleshooting where no manufacturing defect is found.
- Overnight freight or special shipping costs for replacement part(s).
- Overtime, holiday or emergency labor.
- Starting batteries, fuses, light bulbs and engine fluids.

RPV

NOISE
D 3400_{rpm}

Ø 3/4"



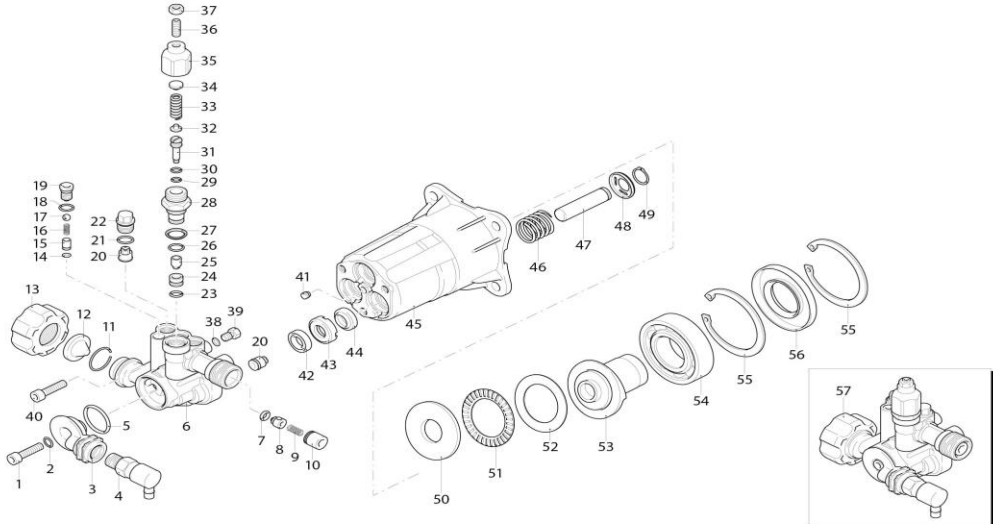





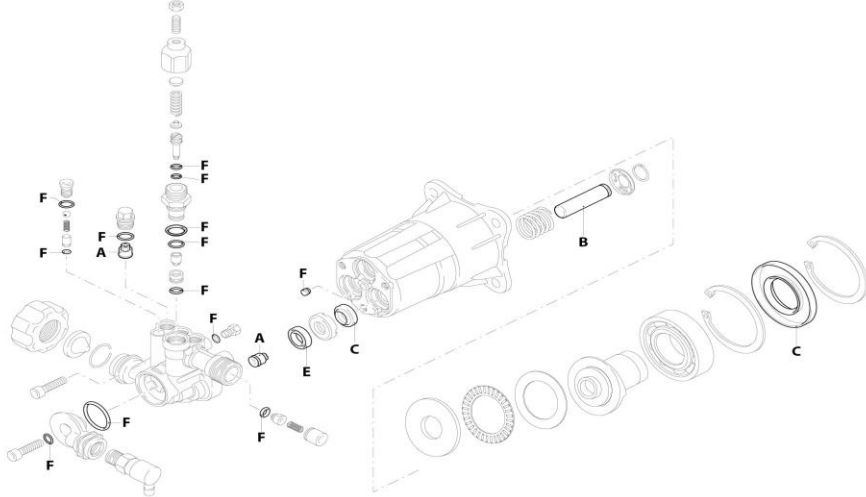



UN00_4100-ER

KIT RICAMBI / PART KITS



A	
B	
C	
D	
E	
F	
G	
H	

UN00_4101-ER

1

40

382 Series

RPV 3400 rpm D version ø 3/4"

2G19 (24965)



Pos.	Cod.	Denominazione	Description	Qt	Note	Pos.	Cod.	Denominazione	Description	Qt	Note
1	780060	Vite	TCEI M6x25	Screw	1	C=1Nm	43	3820230	Boccola	Bushing	3
2	480480	Guarnizione OR	Ø 4,48x1,78	O-ring	1		44	1683500	Tenuta olio	Oil seal	3
3	3820280	Tappo		Plug	1		45	3820010	Corpo pompa	Pump body	1
4	2761380	Valvola		Valve	1	C=10Nm	46	3820300	Molla	Spring	3
5	770260	Guarnizione OR	Ø 23,52x1,78	O-ring	1		47	3820062	Pistone Ø 12	Piston	3
6	3820020	Testa		Head	1		48	3820132	Piattello	Wobble plate	3
7	2560870	Guarnizione OR	Ø 4,7x2	O-ring	1		49	3720390	Anello	Ring	3
8	2101201	Valvola		Valve	1		50	3820110	Ralla	Fifth wheel	1
9	1343581	Molla		Spring	1		51	3820100	Ralla	Fifth wheel	1
10	2101480	Fermo		Lock	1	C=10Nm	52	3820090	Ralla	Fifth wheel	1
11	3820120	Anello		Ring	1		53	3820080	Piattello 13,5°	Wobble plate	1
12	1266330	Filtro		Filter	1		54	200380	Cuscinetto	Bearing	1
13	2841220	Raccordo	3/4"NH	Fitting	1		55	200390	Anello seeger Øi 62	Ring	2
14	3720750	Guarnizione OR	Ø 4x1	O-ring	1		56	3820070	Anello	Ring	1
15	3720740	Sede		Seat	1		57	3829200	Premontaggio testa	Head assembly	1
16	3720760	Molla		Spring	1						
17	1982240	Sfera		Ball	1						
18	1682800	Guarnizione OR	Ø 6x1,5	O-ring	1						
19	3820290	Tappo		Plug	1	C=4Nm					
20	3829050	Valvola		Valve	6						
21	880840	Guarnizione OR	Ø 9,25x1,78	O-ring	3						
22	3820051	Tappo		Plug	3	C=16Nm					
23	660190	Guarnizione OR	Ø 6,07x1,78	O-ring	1						
24	3820370	Sede		Seat	1						
25	3820360	Pistone inferiore		Piston	1	C=3Nm					
26	1121160	Guarnizione OR	Ø 6,86x1,78	O-ring	1						
27	394280	Guarnizione OR	Ø 12,42x1,78	O-ring	1						
28	3820350	Guida pistone		Piston guide	1	C=14Nm					
29	2102640	Guarnizione OR	Ø 4x2	O-ring	1						
30	2560870	Guarnizione OR	Ø 4,7x2	O-ring	1						
31	3820340	Pistone superiore		Piston	1						
32	3820330	Piattello		Wobble plate	1						
33	3820390	Molla		Spring	1						
34	1980220	Piattello		Wobble plate	1						
35	3820380	Inserto		Insert	1						
36	3820550	Vite	M6x16	Screw	1						
37	1060120	Dado	M6	Nut	1						
38	3201760	Guarnizione OR	Ø 4x1,5	O-ring	1						
39	3720720	Tappo		Plug	1	C=4Nm					
40	780060	Vite	TCEI M6x25	Screw	3	C=10Nm					
41	3820310	Tappo		Plug	1						
42	2841910	Tenuta acqua		Water seal	3						

KIT RICAMBI - PART KITS

SIMBOLOGIA - SYMBOLS

A=KIT 43025 valvole valves		B=KIT 43026 ø 12 pistoni pistons		C=KIT 43027 tenute olio oil seals		E=KIT 43028 ø 12 tenute acqua water seals	
Pos.	Q.ty	Pos.	Q.ty	Pos.	Q.ty	Pos.	Q.ty
20	6	47	3	44	3	42	3
				56	1		

F=KIT 43029 OR O-Rings							
Pos.	Q.ty	Pos.	Q.ty	Pos.	Q.ty	Pos.	Q.ty
2	1	26	1				
5	1	27	1				
7	1	29	1				
14	1	30	1				
18	1	38	1				
21	3	41	1				
23	1						

- C Tolleranza coppia di serraggio 0=10% / Tightening torque tolerance 0=10%
- Avvitare con Loxeal 55-14 / Screw with Loxeal 55-14
- Lubrificare con grasso Molykote PG54 / Lubricate with grease Molykote PG54
- Lubrificare con grasso Molykote G807 / Lubricate with grease Molykote G807

Olio - Oil	
Tipo / Type	Quantità / Quantity
SAE 15W40	0,03 Kg

RMV

NOISEA

D 3400rpm

Ø 3/4"

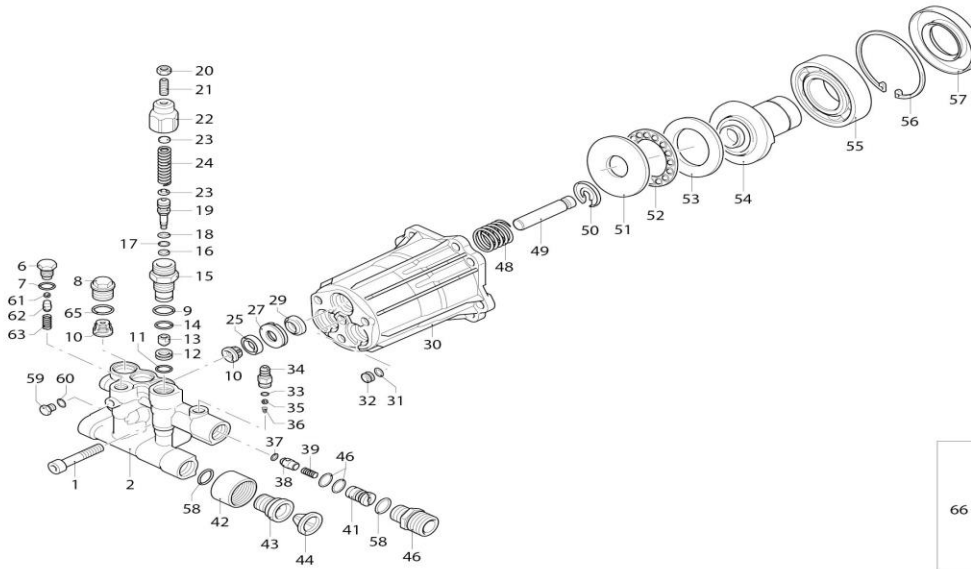

UN002779-AS

KIT RICAMBI / PART KITS

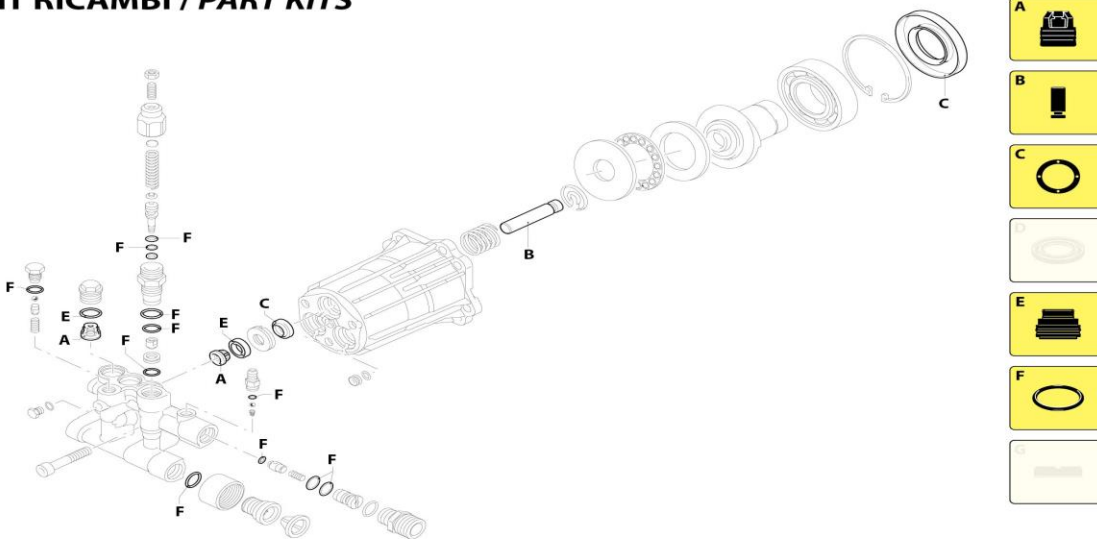

UN002780-AS

02845602

284 Series

2 G20
2.2 G24

RMV 3400 rpm D version ø 3/4" - Alluminium



Pos.	Cod.	Denominazione	Description	Qt	Note	Pos.	Cod.	Denominazione	Description	Qt	Note
1	380410	Vite	TCEI M8x40	3	C=25Nm	46	2840400	Raccordo	3/8" G(M)-M22x1,5(M)	1	☒ C=25Nm
2	2840022	Testa	Head	1			2841380	Raccordo		1	■ C=25Nm
6	2840830	Vite	Screw	1	☒ C=10Nm	48	2840060	Molla	Spring	3	
7	600180	Guarnizione OR	Ø 7,66x1,78	1		49	2840040	Pistone	Ø 12	3	
8	2840481	Tappo	Plug	3	☒ ☐ C=15Nm	50	2840050	Piattello	Wobble plate	3	
9	2841530	Tappo	Plug	3	■ ☒ C=25Nm	51	1980130	Ralla	Fifth wheel	1	
9	740290	Guarnizione OR	Ø 14x1,78	1		52	1980250	Ralla	Fifth wheel	1	
10	2849051	Valvola completa	Complete valve	6		53	1980240	Ralla	Fifth wheel	1	
11	1470210	Guarnizione OR	Ø 9x1	1		54	2840900	Piattello	11" marcato 7	1	☒
12	2840770	Sede	Seat	1			2840720	Piattello	12" marcato 5	1	■
13	2840760	Otturatore	Shutter	1	☒ C=3Nm	55	161060	Cuscinetto	Bearing	1	
14	820510	Guarnizione OR	Ø 10,82x1,78	1		56	161050	Anello	seeger Ø1 72	1	
15	2840750	Guida pistone	Piston guide	1	☒ C=20Nm	57	2841050	Anello	tenuta	1	
16	2760210	Anello antiestrusione	Ring	1		58	2840890	Guarnizione OR	Ø 14x2	2	
17	660190	Guarnizione OR	Ø 6,07x1,78	1		59	2840840	Tappo	Plug	1	☒ C=4Nm
18	2260100	Guarnizione OR	Ø 6,02x2,62	1	☐	60	480650	Rondella	Washer	1	
19	2841140	Pistone	Piston	1		61	1060100	Sfera	Ball	1	■
20	1060120	Dado	M6	1		62	2840440	Sede	Seat	1	■
21	392840	Vite	M6x16	1		63	2840450	Molla	Spring	1	■
22	2760480	Inserito	Insert	1		65	2841200	Guarnizione OR	Ø 13,5x1,8	3	
23	1980220	Piattello	Wobble plate	2		66	2849284	Premontaggio testa	Head assembly	1	■
24	2760410	Molla	Spring	1							
25	2200141	Tenuta acqua	Water seal	3	☒						
27	2840561	Boccola	Bushing	3							
29	1683500	Tenuta olio	Oil seal	3							
30	2840230	Corpo pompa	Pump body	1							
31	480560	Guarnizione OR	Ø 6,75x1,78	1							
32	2840710	Tappo	Plug	1							
33	480480	Guarnizione OR	Ø 4,48x1,78	1							
34	1982520	Portagomma	Hose tail	1	C=4Nm						
35	1250280	Sfera	Ball	1							
36	1560520	Molla	Spring	1							
37	1460431	Guarnizione OR	Ø 4x2,5	1	☒						
38	2841150	Otturatore	Shutter	1							
39	1343580	Molla	Spring	1							
40	800560	Guarnizione OR	Ø 8,73x1,78	2							
41	2840340	Iniettore	Injector	1							
42	2840270	Raccordo	Fitting	1	3/4" NH						
43	2841230	Raccordo	Fitting	1	☒ ☒ C=25Nm						
43	2840390	Raccordo	Fitting	1	■ ☒ C=25Nm						
44	1266330	Filtro	Filter	1							

KIT RICAMBI - PART KITS

A=KIT 2233 valvole valves		B=KIT 2234 ø 12 pistoni pistons		C=KIT 42127 tenute olio oil seals		E=KIT 42122 ø 12 tenute acqua water seals	
Pos.	Q.ty	Pos.	Q.ty	Pos.	Q.ty	Pos.	Q.ty
10	6	49	3	29	3	25	3
				57	1		

F=KIT 2237 OR O-Rings			
Pos.	Q.ty	Pos.	Q.ty
7	1	37	1
9	1	40	2
11	1	58	2
14	1	65	3
17	1		
18	1		
33	1		

SIMBOLOGIA - SYMBOLS

☒ Per / For RMV 2 G20 D	■ Per / For RMV 2.2 G24 D
----------------------------	------------------------------

- C Tolleranza coppia di serraggio 0-+10% / Tightening torque tolerance 0-+10%
- ☒ Avvitare con Loxeal 55-14 / Screw with Loxeal 55-14
- ☒ Lubrificare con grasso Molykote PG54 / Lubricate with grease Molykote PG54
- ☐ Lubrificare con grasso Molykote G807 / Lubricate with grease Molykote G807
- ☒ Avvitare con Loxeal 83-55 / Screw with Loxeal 83-55

Olio - Oil	
Tipo / Type	Quantità / Quantity
SAE 15W40	0,65 Kg

M91607

2

RQV

NOISEA

D 3400_{rpm}

Ø 3/4"

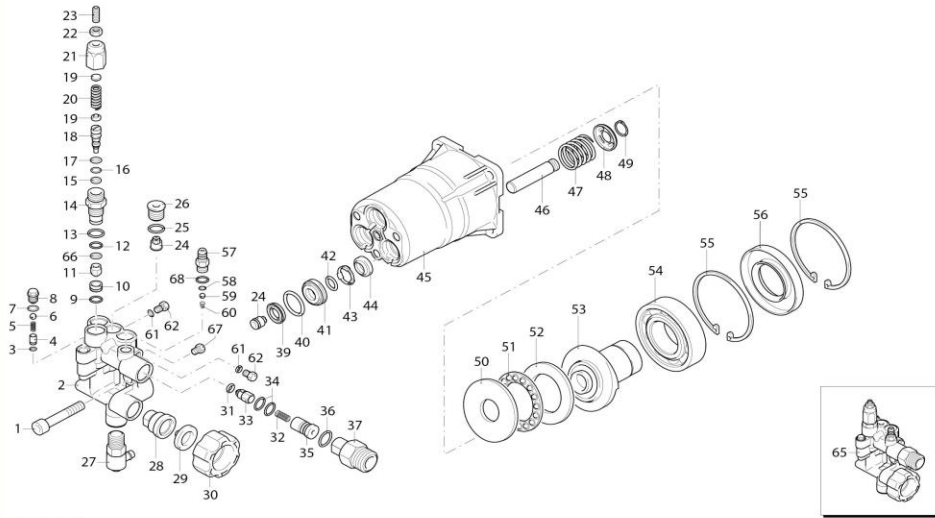

UN004048-FS

KIT RICAMBI / PART KITS

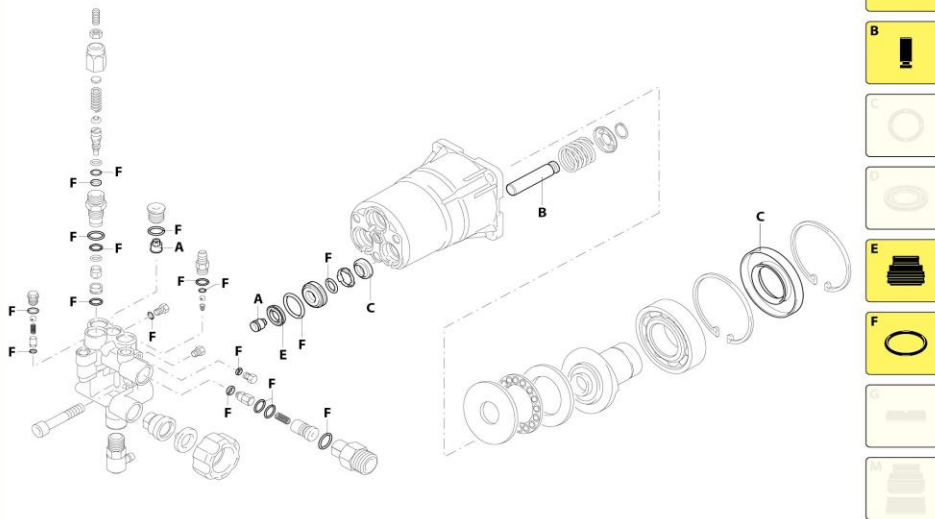

UN004049-FS

37786000

372 Series

2.5 G30

RQV 3400 rpm D version ø 3/4"



Pos.	Cod.	Denominazione	Description	Qt	Note	Pos.	Cod.	Denominazione	Description	Qt	Note
1	380410	Vite TCEI M8x40	Screw	3	C=20Nm	44	1683500	Tenuta olio	Oil seal	3	
2	3720770	Testa ottone	Head	1		45	3720790	Corpo pompa	Pump body	1	
3	3720750	Guarnizione OR Ø 4x1	O-ring	1		46	3720340	Pistone Ø 12	Piston	3	
4	3720740	Sede	Seat	1		47	3720380	Molla	Spring	3	
5	3720760	Molla	Spring	1		48	3720360	Fermo	Lock	3	
6	1250280	Sfera	Ball	2		49	3720390	Anello	Ring	3	
7	1682800	Guarnizione OR Ø 6x1,5	O-ring	1		50	1980130	Ralla	Fifth wheel	1	
8	3720730	Tappo	Plug	1	C=4Nm	51	1980250	Ralla	Fifth wheel	1	
9	1470210	Guarnizione OR Ø 9x1	O-ring	1		52	1980240	Ralla	Fifth wheel	1	
10	3720500	Sede	Seat	1		53	2841190	Piattello 13° marcato 3	Wobble plate	1	
11	3720520	Otturatore	Shutter	1	C=3Nm	54	161060	Cuscinetto	Bearing	1	
12	3720560	Guarnizione OR Ø 4,5x1,5	O-ring	1		55	161050	Anello seeger Øi 72	Ring	2	
13	394280	Guarnizione OR Ø 12,42x1,78	O-ring	1		56	2841050	Anello tenuta	Ring	1	
14	3720620	Guida pistone	Piston guide	1	C=20Nm	57	3700240	Portagomma Ø 8	Hose tail	1	C=4Nm
15	3720570	Guarnizione OR Ø 9x1,5	O-ring	1		58	480480	Guarnizione OR Ø 4,48x1,78	O-ring	1	
16	660190	Guarnizione OR Ø 6,07x1,78	O-ring	1		60	1560520	Molla	Spring	1	
17	3720600	Anello antiestrusione	Ring	1		61	3201760	Guarnizione OR Ø 4x1,5	O-ring	2	C=4Nm
18	3720540	Otturatore	Shutter	1		62	3720720	Tappo	Plug	2	
19	3720660	Piattello	Wobble plate	2		65	3729200	Premontaggio testa	Head assembly	1	
20	3720640	Molla	Spring	1		66	3720580	Anello antiestrusione	Ring	1	
21	3720681	Guida	Guide	1		67	3720830	Tappo gomma	Plug	1	
22	1060120	Dado M6	Nut	1		68	3700250	Guarnizione OR Ø 8x1,1	O-ring	1	80 ShA
23	392840	Vite M6x16	Screw	1							
24	2849053	Valvola completa	Complete valve	6							
25	770140	Guarnizione OR Ø 11,11x1,78	O-ring	3							
26	3720441	Tappo	Plug	3	C=20Nm						
27	2761380	Valvola	Valve	1	C=16Nm						
28	2841230	Raccordo alluminio	Fitting	1	C=25Nm						
29	1266330	Filtro	Filter	1							
30	2841220	Raccordo 3/4"NH	Fitting	1							
31	1460431	Guarnizione OR Ø 4x2,5	O-ring	1							
32	3700210	Molla	Spring	1							
33	3700220	Valvola	Valve	1							
34	800560	Guarnizione OR Ø 8,73x1,78	O-ring	2							
35	3700200	Iniettore	Injector	1							
36	2840890	Guarnizione OR Ø 14x2	O-ring	2							
37	2841120	Raccordo	Fitting	1	C=25Nm						
39	2200141	Tenuta acqua	Water seal	3							
40	770590	Guarnizione OR Ø 21,95x1,78	O-ring	3							
41	3720410	Boccola	Bushing	3							
42	3660340	Guarnizione OR Ø 12x2	O-ring	3							
43	3720400	Distanziale	Spacer	3							

KIT RICAMBI - PART KITS

A=KIT 42955 valvole valves		B=KIT 42956 ø 12 pistoni pistons		C=KIT 42960 tenute olio oil seals		E=KIT 42958 ø 12 tenute acqua water seals	
Pos.	Q.ty	Pos.	Q.ty	Pos.	Q.ty	Pos.	Q.ty
24	6	46	3	44	3	39	3
				56	1		

F=KIT 42959 OR O-Rings							
Pos.	Q.ty	Pos.	Q.ty	Pos.	Q.ty	Pos.	Q.ty
3	1	25	3	61	2		
7	1	31	1	68	1		
9	1	34	2				
12	1	36	2				
13	1	40	3				
15	1	42	3				
16	1	58	1				

SIMBOLOGIA - SYMBOLS

- C Tolleranza coppia di serraggio 0±10% / Tightening torque tolerance 0±10%
- Avvitare con Loxeal 55-14 / Screw with Loxeal 55-14
- Lubrificare con grasso Molykote PG54 / Lubricate with grease Molykote PG54
- Avvitare con Loxeal 83-55 / Screw with Loxeal 83-55

Olio - Oil

Tipo / Type	Quantità / Quantity
SAE 75W90	0,065 Kg

MI

10

(CI_24-OTT-2013_R.A.)

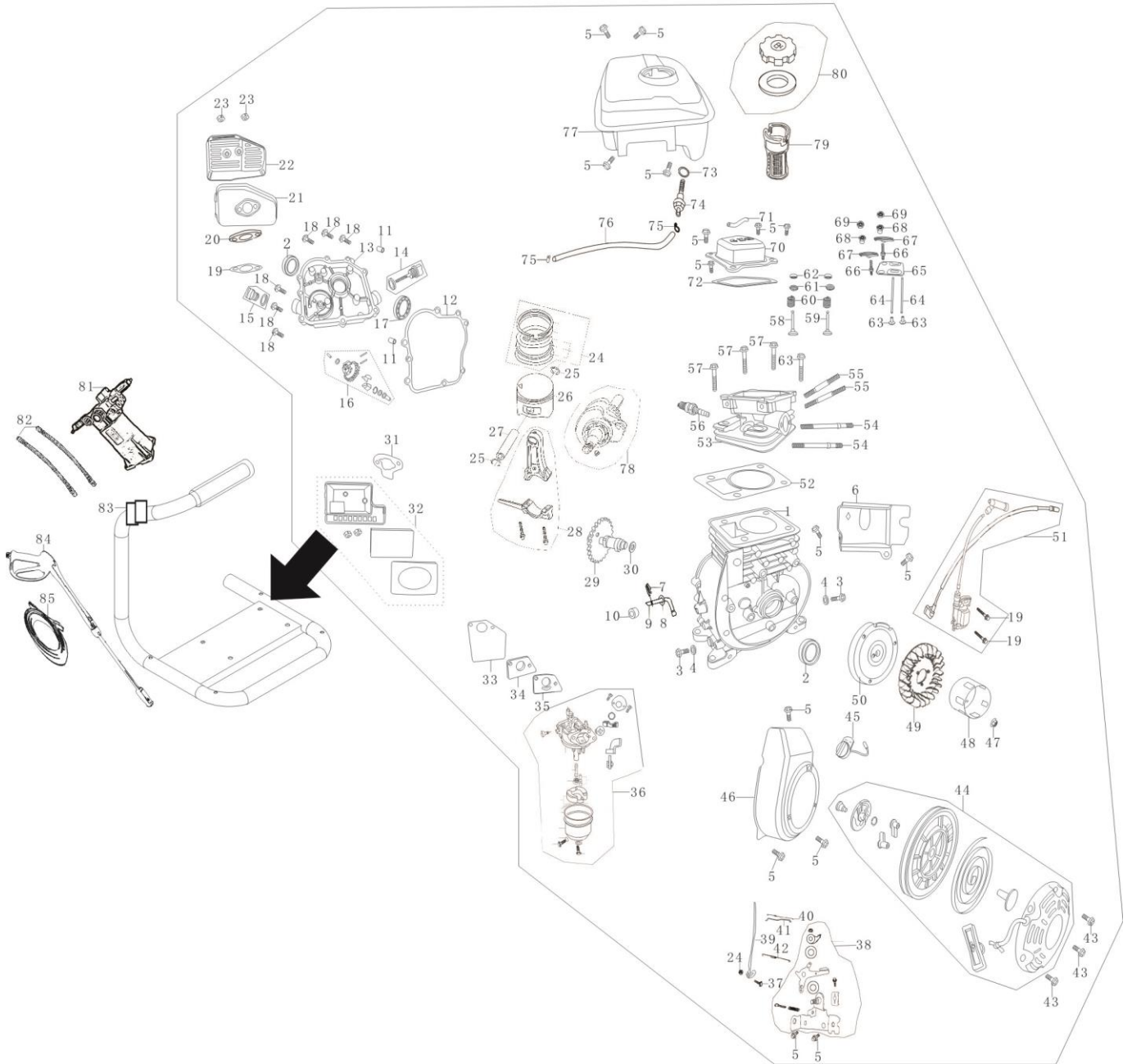

Part	Code	Description	q'ty
1	11110-A0430-0001	Crankcase	1
2	11120-A0410-0002	Oil seal (17X30X6) ,crankshaft	2
3	11115-A0710-0001	Drian plug	2
4	11116-A0710-0001	Washer	2
5	T151-0002	Bolt M6X12	15
6	19121-A0430-0001	Flow guard	1
7	26112-A0410-0001	Keeper,sway bar	1
8	26113-A0410-0001	Washer,sway bar	1
9	26111-A0410-0001	sway bar	1
10	11130-A0410-0001	Oil seal,sway bar	1
11	11113-A0710-0001	Set pin ϕ 8X14	2
12	11114-A0430-0001	Gasket,crankcase	1
13	11211-A0430-0001	Crankcase cover	1
14	15510-A0710-0001	Dipstick sub-assy	1
15	15610-A0710-0001	Oil plug sub-assy	1
16	25100-A0410-0001	Driven gear sub-assy,governor	1
17	T910-0006	Bearing 6203	1
18	T151-0021	Bolt M6X28	8
19	18215-BT2Y0-0001	Gasket,exhaust port	1
20	18221-A0430-0001	Muffler block	1
21	18000-A0430-0001	Muffler	1
22	18130-A0430-0001	Muffler hood	1
23	T311-0002	Nut M6	3
24	13400-A0410-0001	Piston ring set	1
25	13313-A0410-0001	Circlip,piston pin	2
26	13311-A0410-0001	Piston	1
27	13312-A0410-0001	Piston pin	1
28	13120-A0410-0001	Connecting rod	1
29	14100-A0410-0001	Camshaft	1
30	14114-A0410-0001	Washer,camshaft	1
31	17113-A0410-0001	Gasket,air cleaner	1
32	17100-A0430-0001	Housing,air cleaner	1
33	17219-A0430-0001	Gasket,intake port	1
34	16120-A0430-0001	Connecting block	1
35	16113-A0430-0001	Gasket, carburetor	1
36	16100-A0430-0001	Carburetor assy	1
37	26116-A0710-0001	Lock bolt	1
38	26200-A0430-0001	Mount, governor	1
39	26114-A0430-0001	Governor arm	1
40	26118-A0410-0001	Assistant spring, governor	1
41	26115-A0410-0001	Pull-rod, governor	1
42	26117-A0410-0001	Return spring	1
43	T151-0023	Bolt M6×8	3

44	23100-A0430-0003	Recoil starter	1
45	27300-A0410-0001	Engine switch	1
46	192110-BT2Y0-0005	Fan hood sub-assy	1
47	23317-A0410-0001	Nut M12×1.25	1
48	23316-A0430-0001	Starting flange	1
49	19111-A0410-0001	Fan, flywheel	1
50	23300-A0430-0001	Flywheel	1
51	27200-A0430-0001	Ignition coil sub-assy	1
52	12120-A0430-0001	Gasket, cylinder head	1
53	12100-A0430-0001	Cylinder head Assy	1
54	18214-A1820-0001	Stud M6×90	2
55	17218-A0430-0001	Stud M5×90	2
56	27100-A0410-0004	Spark plug 255	1
57	12118-A0430-0003	Bolt	4
58	14411-A0430-0001	Intake valve	1
59	14412-A0430-0001	Exhaust valve	1
60	14414-A0430-0001	Valve spring	2
61	14415-A0410-0001	Spring seat, valve	2
62	14416-A0430-0001	Cap	2
63	14315-A0430-0001	Tappet	2
64	14210-A0430-0001	Pusher	2
65	14220-A0430-0001	Pusher guide	1
66	14313-A0430-0001	Adjusting bolt for valve gap	2
67	14310-A0430-0001	Valve rocker	2
68	14312-A0430-0001	Sleeve	2
69	14314-A0710-0001	Lock nut	2
70	12200-A0430-0001	Cylinder head cover Assy	1
71	19143-A0430-0001	Air duck	1
72	12120-A0430-0001	Gasket, cylinder head cover	1
73	16630-A0710-0001	Seal ring, outlet nipple	1
74	16630-A0710-0001	Outlet nipple	1
75	16622-A0710-0005	Pipe clamp	2
76	16623-A0721-0001	Outlet pipe	1
77	16510-A0430-0031	Fuel tank	1
78	13110-A0430-0006	Crankshaft sub-assy	1
79	16610-A0430-0001	Filter cup	1
80	16400-A2010-0005	Fuel filler cap sub-assy	1
81	55600-E1110-0002	High pressure pumps	1
82	55511-E4310-0001	High pressure hose	2
83	55100-E1110-0002	Wand assy	1
84	55550-E8310-0001	Frame	1
85	55520-E1110-0002	Outlet hose	1

Q2265

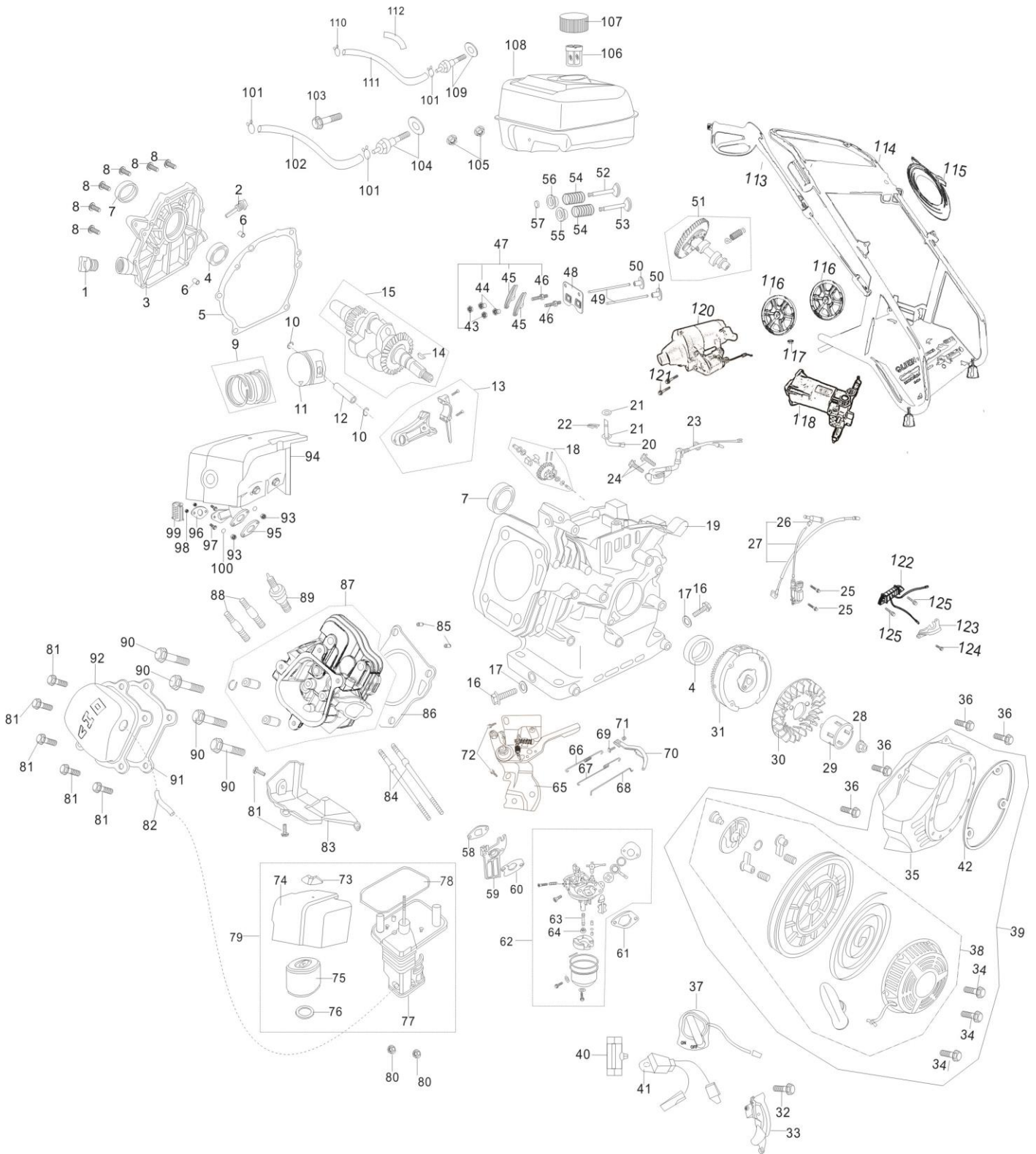

Part	Code	Description	q'ty
1	15610-A0710-0001	Oil plug with Seal	1
2	15510-A0710-0001	Dipstick with seal	1
3	11211-A0710-0001	Crankcase cover	1
4	T910-0001	Bearing 6205	2
5	11114-A0710-0001	Gasket, crankcase	1
6	11113-A0710-0001	Set pinφ8×14	1
7	11120-A0710-0001	Oil seal, crankshaft	2
8	T151-0001	Bolt M8×32	6
9	13400-A0730-0001	Piston ring assy	1
10	13313-A0710-0001	Piston pin circlip	2
11	13311-A0720-0004	Piston	1
12	13312-A0710-0001	Piston pin	1
13	13120-A0710-0001	Shank	1
14	13112-A0710-0001	Woodruff key	1
15	13110-A0720-0005	Crankshaft assy	1
16	11115-A0710-0001	Drain plug M10X15	2
17	11116-A0710-0001	Washer	2
18	25100-A0710-0004	Driven gear assy, regulator	1
19	11110-A0720-0017	Crankcase	1
20	26111-A0710-0001	Regulating sway bar	1
21	26113-A0710-0001	Washer	2
22	26112-A0710-0001	Split pin	1
23	27400-A0710-0002	Oil sensor	1
24	T152-0004	Bolt M6×14	2
25	T151-0011	Screw M6×25	2
26	27220-A0410-0001	Spark plug cap	1
27	27200-A0710-0001	Ignition coil assy	1
28	23317-A0710-0001	Nut M14×1.5	1
29	23316-A0710-0002	Starting flange	1
30	19111-A0710-0001	Flywheel fan	1
31	23300-A0710-0007	Flywheel	1
32	T152-0033	Bolt M6×22	1
33	19300-A0710-0001	Crankcase side plate assy	1
34	T210-0005	Bolt M5×8	3
35	19211-A07Y2-0012	Fan hood assy	1
36	T152-0019	Bolt M6×12	4
37	27300-A0712-0001	Engine switch	1
38	23200-A0721-0018	Recoil starter	1
39	23100-A07Y9-0016	Recoil starter assy	1
40	19313-A0710-0001	Plastic clip	1
41	27500-A0710-0001	Diode	1
42	23260-A0710-0001	Recoil spacer combination	1
43	14314-A0710-0001	Lock nut	2
44	14312-A0710-0001	Sleeve	2
45	14311-A0710-0001	Valve rocker	2

46	14313-A0710-0001	Adjusting bolt for valve gap	2
47	14310-A0710-0001	Valve rocker assy	2
48	14220-A0710-0001	Pusher guide	1
49	14210-A0710-0001	Pusher	2
50	14315-A0720-0001	Tappet	2
51	14100-A0720-0005	Camshaft Assy	1
52	14412-A0710-0001	Exhaust valve	1
53	14411-A0710-0001	Intake valve	1
54	14414-A0710-0001	Valve spring	2
55	14413-A0710-0001	Spring seat, intake valve	1
56	14415-A0710-0001	Spring seat, exhaust valve	1
57	14416-A0710-0001	Cap	1
58	17219-A0710-0001	Inlet gasket	1
59	16120-A0710-0001	Connecting block	1
60	16113-A0710-0001	Carburetor gasket	1
61	17113-A0710-0001	Air cleaner gasket	1
62	16100-A0720-0021	Carburetor Assy	1
63	16244-A0720-0001	Main nozzle	1
64	16243-A0720-0001	Main je	1
65	26200-A0710-0011	Regulating frame assy	1
66	26117-A0710-0001	Back spring	1
67	26118-A0710-0001	Fine regutaling spring	1
68	26115-A0710-0001	Pulling rod	1
69	26116-A0710-0001	Lock bolt	1
70	26114-A0710-0001	Regulating arm	1
71	T354-0002	Nut M6	1
72	T152-0019	Bolt M6×12	2
73	17111-A0712-0001	Air cleaner cover nut	1
74	17112-A0712-0001	Air cleaner cover	1
75	17120-A0710-0001	Filter element	1
76	17121-A0710-0001	Washer	1
77	17200-A0710-0002	Air cleaner housing	1
78	17129-A0710-0001	Gasket	1
79	17100-A0712-0008	Air cleaner assy	1
80	T311-0002	Nut M6	2
81	T152-0019	Bolt M6×22	6
82	19143-A0710-0001	Air duck	1
83	19121-A0721-0001	Lead wind cover	1
84	17218-A0710-0001	Stud M6×96	2
85	12117-A0710-0001	Set pinφ10×16	2
86	12120-A0721-0001	Gasket, cylinder head	1
87	12100-A0721-0004	Cylinder head Assy	1
88	18214-A0710-0001	Stud M8×34	2
89	27100-A0710-0001	Spark plug F6TC	1
90	12118-A0710-0001	Bolt	4
91	12212-A0721-0001	Gasket, cylinder head cover	1

92	12200-A0721-0001	Cylinder head cover Assy	1
93	T310-0001	Nut M8	2
94	18000-A0712-0013	Muffler	1
95	18215-A0710-0001	Exhaust gasket	1
96	18172-A0710-0001	Fill valve gasket	1
97	T152-0033	Stud M6×22	2
98	T314-0001	Nut M6	2
99	18171-A0710-0001	Fill valve	1
100	T441-0001	Spring washer	2
101	16622-A0710-0002	Pipe clamp 8mm-10mm	3
102	16621-A0710-0020	Outlet pipe	1
103	T152-0011	Bolt M6×28	1
104	16630-A0710-0001	Connector	1
105	T311-0002	Nut M6	2
106	16610-A0710-0003	Filter cup	1
107	16400-A0410-0002	Fuel filler cap with packing ring	1
108	16510-A0712-0081	Fuel tank	1
109	16557-A0710-0001	Outlet connector	1
110	16622-A0710-0003	Pipe clamp 10mm-14mm	2
111	11513-A0710-0002	Snorkel	1
112	12158-A0710-0001	Lagging	1
113	55550-E8310-0001	Wand assy	1
114	55100-E4314-0001	Frame	1
115	55511-E4310-0001	High pressure pipe	1
116	45420-B9130-0029	12" Wheel	2
117	T315-0002	Nut (M12)	2
118	55600-E4310-0001	High pressure pump assembly	1
120	24100-A0714-0001	Starting motor Assy	1
121	T151-0008	Bolt, M8×35	2
122	24130-A0714-0001	Charge coil	1
123	24145-A0714-0001	Clamper, cord	1
124	T152-0019	Bolt M6×12	1
125	T152-0030	Bolt M6×30	2

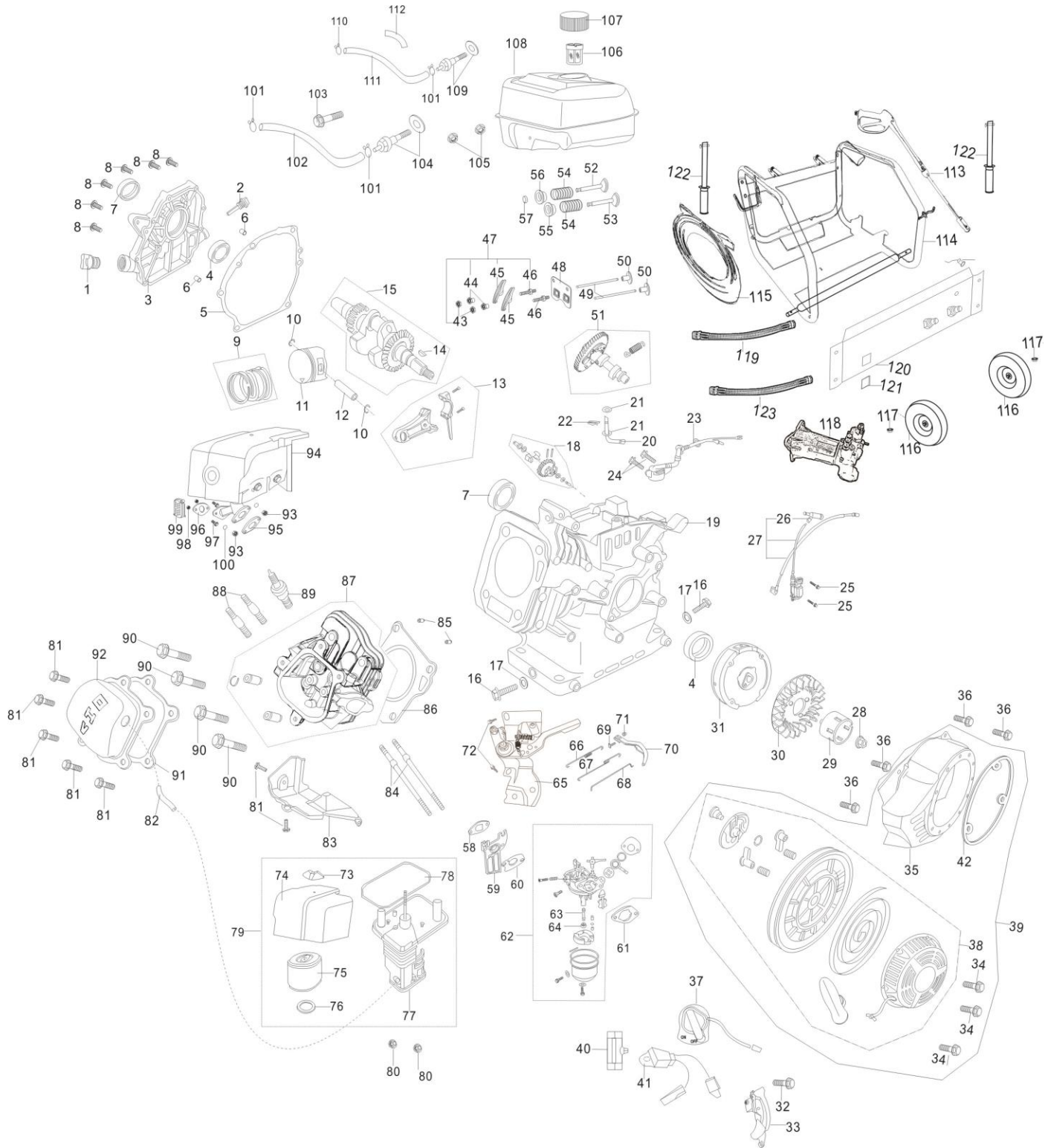

1	15610-A0710-0001	Oil plug with Seal	1
2	15510-A0710-0001	Dipstick with seal	1
3	11211-A0710-0001	Crankcase cover	1
4	T910-0001	Bearing 6205	2
5	11114-A0710-0001	Gasket, crankcase	1
6	11113-A0710-0001	Set pin ϕ 8×14	1
7	11120-A0710-0001	Oil seal, crankshaft	2
8	T151-0001	Bolt M8×32	6
9	13400-A0730-0001	Piston ring assy	1
10	13313-A0710-0001	Piston pin circlip	2
11	13311-A0720-0004	Piston	1
12	13312-A0710-0001	Piston pin	1
13	13120-A0710-0001	Shank	1
14	13112-A0710-0001	Woodruff key	1
15	13110-A0720-0005	Crankshaft assy	1
16	11115-A0710-0001	Drain plug M10X15	2
17	11116-A0710-0001	Washer	2
18	25100-A0710-0004	Driven gear assy, regulator	1
19	11110-A0720-0017	Crankcase	1
20	26111-A0710-0001	Regulating sway bar	1
21	26113-A0710-0001	Washer	2
22	26112-A0710-0001	Split pin	1
23	27400-A0710-0002	Oil sensor	1
24	T152-0004	Bolt M6×14	2
25	T151-0011	Screw M6×25	2
26	27220-A0410-0001	Spark plug cap	1
27	27200-A0710-0001	Ignition coil assy	1
28	23317-A0710-0001	Nut M14×1.5	1
29	23316-A0710-0002	Starting flange	1
30	19111-A0710-0001	Flywheel fan	1
31	23300-A0710-0007	Flywheel	1
32	T152-0033	Bolt M6×22	1
33	19300-A0710-0001	Crankcase side plate assy	1
34	T210-0005	Bolt M5×8	3
35	19211-A0725-0033	Fan hood assy	1
36	T152-0019	Bolt M6×12	4
37	27300-A0712-0001	Engine switch	1
38	23200-A0721-0018	Recoil starter	1
39	23100-A0722-0046	Recoil starter assy	1
40	19313-A0710-0001	Plastic clip	1
41	27500-A0710-0001	Diode	1

42	23260-A0710-0001	Recoil spacer combination	1
43	14314-A0710-0001	Lock nut	2
44	14312-A0710-0001	Sleeve	2
45	14311-A0710-0001	Valve rocker	2
46	14313-A0710-0001	Adjusting bolt for valve gap	2
47	14310-A0710-0001	Valve rocker assy	2
48	14220-A0710-0001	Pusher guide	1
49	14210-A0710-0001	Pusher	2
50	14315-A0720-0001	Tappet	2
51	14100-A0720-0005	Camshaft Assy	1
52	14412-A0710-0001	Exhaust valve	1
53	14411-A0710-0001	Intake valve	1
54	14414-A0710-0001	Valve spring	2
55	14413-A0710-0001	Spring seat, intake valve	1
56	14415-A0710-0001	Spring seat, exhaust valve	1
57	14416-A0710-0001	Cap	1
58	17219-A0710-0001	Inlet gasket	1
59	16120-A0710-0001	Connecting block	1
60	16113-A0710-0001	Carburetor gasket	1
61	17113-A0710-0001	Air cleaner gasket	1
62	16100-A0720-0022	Carburetor Assy	1
63	16244-A0720-0001	Main nozzle	1
64	16243-A0720-0001	Main je	1
65	26200-A0710-0011	Regulating frame assy	1
66	26117-A0710-0001	Back spring	1
67	26118-A0710-0001	Fine regutaling spring	1
68	26115-A0710-0001	Pulling rod	1
69	26116-A0710-0001	Lock bolt	1
70	26114-A0710-0001	Regulating arm	1
71	T354-0002	Nut M6	1
72	T152-0019	Bolt M6×12	2
73	17111-A0712-0001	Air cleaner cover nut	1
74	17112-A0712-0001	Air cleaner cover	1
75	17120-A0710-0001	Filter element	1
76	17121-A0710-0001	Washer	1
77	17200-A0710-0002	Air cleaner housing	1
78	17129-A0710-0001	Gasket	1
79	17100-A0712-0008	Air cleaner assy	1
80	T311-0002	Nut M6	2
81	T152-0019	Bolt M6×22	6
82	19143-A0710-0001	Air duck	1

83	19121-A0721-0001	Lead wind cover	1
84	17218-A0710-0001	Stud M6×96	2
85	12117-A0710-0001	Set pinφ10×16	2
86	12120-A0721-0001	Gasket, cylinder head	1
87	12100-A0721-0004	Cylinder head Assy	1
88	18214-A0710-0001	Stud M8×34	2
89	27100-A0710-0001	Spark plug F6TC	1
90	12118-A0710-0001	Bolt	4
91	12212-A0721-0001	Gasket, cylinder head cover	1
92	12200-A0721-0001	Cylinder head cover Assy	1
93	T310-0001	Nut M8	2
94	18000-A0712-0013	Muffler	1
95	18215-A0710-0001	Exhaust gasket	1
96	18172-A0710-0001	Fill valve gasket	1
97	T152-0033	Stud M6×22	2
98	T314-0001	Nut M6	2
99	18171-A0710-0001	Fill valve	1
100	T441-0001	Spring washer	2
101	16622-A0710-0002	Pipe clamp 8mm-10mm	3
102	16621-A0710-0020	Outlet pipe	1
103	T152-0011	Bolt M6×28	1
104	16630-A0710-0001	Connector	1
105	T311-0002	Nut M6	2
106	16610-A0710-0003	Filter cup	1
107	16400-A0410-0002	Fuel filler cap with packing ring	1
108	16510-A0712-0081	Fuel tank	1
109	16557-A0710-0001	Outlet connector	1
110	16622-A0710-0003	Pipe clamp 10mm-14mm	2
111	11513-A0710-0002	Snorkel	1
112	12158-A0710-0001	Lagging	1
113	55550-E8310-0001	Wand assy	1
114	55100-E8310-0001	Frame	1
115	55511-E8310-0001	High pressure pipe	1
116	45420-E8310-0001	Wheel	2
117	T315-0002	Nut (M12)	2
118	55600-E8310-0001	High pressure pump assembly	1
119	55530-E8310-0003	Inlet pipe assembly	1
120	31211-E8310-0001	Control panel	1
121	31225-B9130-0009	The ignition switch	1
122	32480-BB140-0002	Armrest latch assembly	2
123	55510-E8310-0001	Water Outlet Pipe Components	1

Q3370E

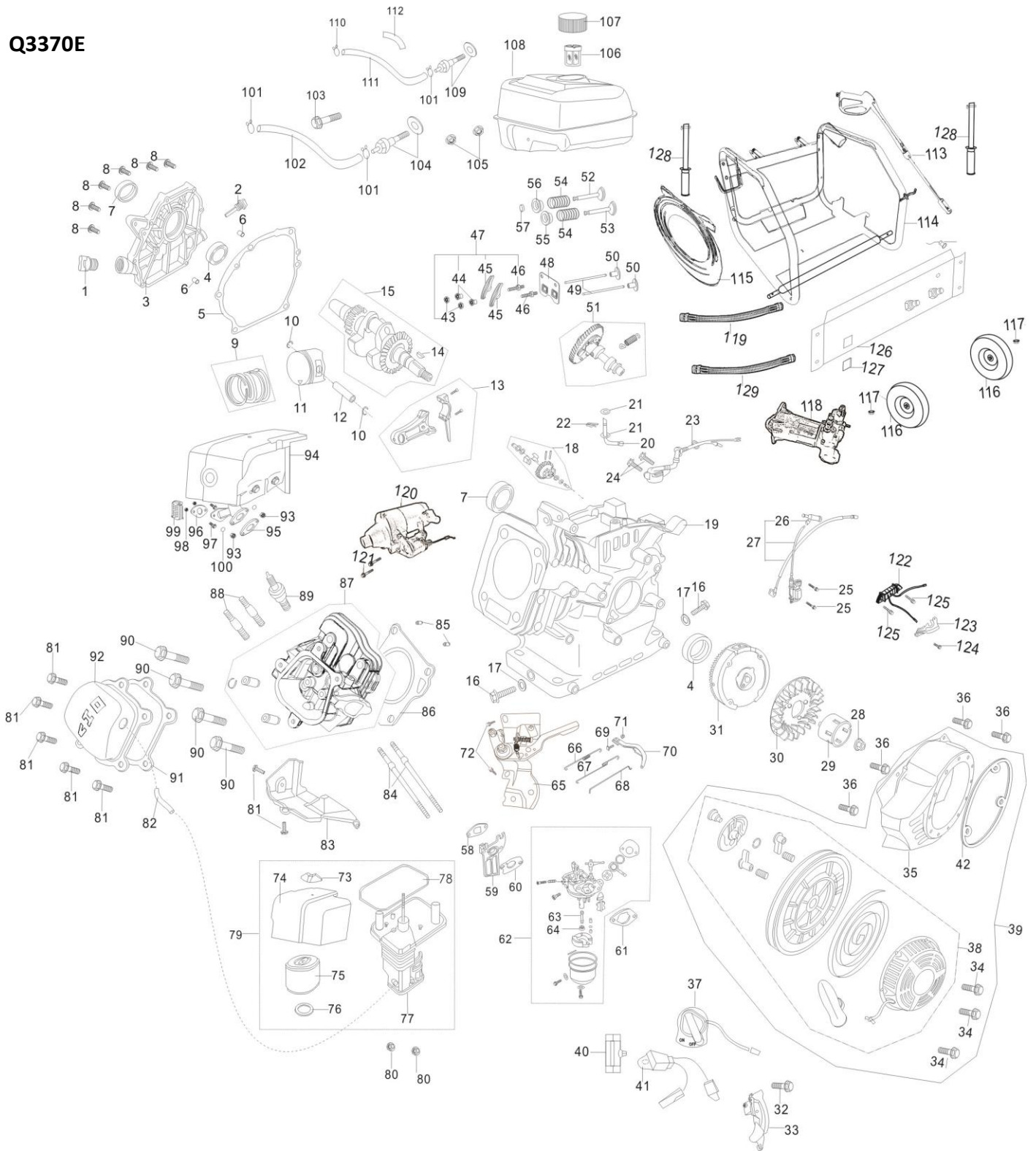

1	15610-A0710-0001	Oil plug with Seal	1
2	15510-A0710-0001	Dipstick with seal	1
3	11211-A0710-0001	Crankcase cover	1
4	T910-0001	Bearing 6205	2
5	11114-A0710-0001	Gasket, crankcase	1
6	11113-A0710-0001	Set pin ϕ 8×14	1
7	11120-A0710-0001	Oil seal, crankshaft	2
8	T151-0001	Bolt M8×32	6
9	13400-A0730-0001	Piston ring assy	1
10	13313-A0710-0001	Piston pin circlip	2
11	13311-A2310-0002	Piston	1
12	13312-A0710-0001	Piston pin	1
13	13120-A0710-0001	Shank	1
14	13112-A0710-0001	Woodruff key	1
15	13110-A2310-0009	Crankshaft assy	1
16	11115-A0710-0001	Drain plug M10X15	2
17	11116-A0710-0001	Washer	2
18	25100-A0710-0004	Driven gear assy, regulator	1
19	11110-A2310-0011	Crankcase	1
20	26111-A0710-0001	Regulating sway bar	1
21	26113-A0710-0001	Washer	2
22	26112-A0710-0001	Split pin	1
23	27400-A0710-0002	Oil sensor	1
24	T152-0004	Bolt M6×14	2
25	T151-0011	Screw M6×25	2
26	27220-A0410-0001	Spark plug cap	1
27	27200-A0710-0001	Ignition coil assy	1
28	23317-A0710-0001	Nut M14×1.5	1
29	23316-A0710-0002	Starting flange	1
30	19111-A0710-0001	Flywheel fan	1
31	23300-A0710-0007	Flywheel	1
32	T152-0033	Bolt M6×22	1
33	19300-A0710-0001	Crankcase side plate assy	1
34	T210-0005	Bolt M5×8	3
35	19211-A07Y2-0012	Fan hood assy	1
36	T152-0019	Bolt M6×12	4
37	27300-A0712-0001	Engine switch	1
38	23200-A0721-0018	Recoil starter	1
39	23100-A07Y9-0016	Recoil starter assy	1
40	19313-A0710-0001	Plastic clip	1
41	27500-A0710-0001	Diode	1
42	23260-A0710-0001	Recoil spacer combination	1
43	14314-A0710-0001	Lock nut	2
44	14312-A0710-0001	Sleeve	2
45	14311-A0710-0001	Valve rocker	2
46	14313-A0710-0001	Adjusting bolt for valve gap	2

47	14310-A0710-0001	Valve rocker assy	2
48	14220-A0710-0001	Pusher guide	1
49	14210-A0710-0001	Pusher	2
50	14315-A0720-0001	Tappet	2
51	14100-A0720-0005	Camshaft Assy	1
52	14412-A0710-0001	Exhaust valve	1
53	14411-A0710-0001	Intake valve	1
54	14414-A0710-0001	Valve spring	2
55	14413-A0710-0001	Spring seat, intake valve	1
56	14415-A0710-0001	Spring seat, exhaust valve	1
57	14416-A0710-0001	Cap	1
58	17219-A0710-0001	Inlet gasket	1
59	16120-A0710-0001	Connecting block	1
60	16113-A0710-0001	Carburetor gasket	1
61	17113-A0710-0001	Air cleaner gasket	1
62	16100-A0720-0022	Carburetor Assy	1
63	16244-A0720-0001	Main nozzle	1
64	16243-A0720-0001	Main je	1
65	26200-A0710-0011	Regulating frame assy	1
66	26117-A0710-0001	Back spring	1
67	26118-A0710-0001	Fine regutaling spring	1
68	26115-A0710-0001	Pulling rod	1
69	26116-A0710-0001	Lock bolt	1
70	26114-A0710-0001	Regulating arm	1
71	T354-0002	Nut M6	1
72	T152-0019	Bolt M6×12	2
73	17111-A0712-0001	Air cleaner cover nut	1
74	17112-A0712-0001	Air cleaner cover	1
75	17120-A0710-0001	Filter element	1
76	17121-A0710-0001	Washer	1
77	17200-A0710-0002	Air cleaner housing	1
78	17129-A0710-0001	Gasket	1
79	17100-A0712-0008	Air cleaner assy	1
80	T311-0002	Nut M6	2
81	T152-0019	Bolt M6×22	6
82	19143-A0710-0001	Air duck	1
83	19121-A0721-0001	Lead wind cover	1
84	17218-A0710-0001	Stud M6×96	2
85	12117-A0710-0001	Set pinφ10×16	2
86	12120-A0721-0001	Gasket, cylinder head	1
87	12100-A0721-0004	Cylinder head Assy	1
88	18214-A0710-0001	Stud M8×34	2
89	27100-A0710-0001	Spark plug F6TC	1
90	12118-A0710-0001	Bolt	4
91	12212-A0721-0001	Gasket, cylinder head cover	1
92	12200-A0721-0001	Cylinder head cover Assy	1

93	T310-0001	Nut M8	2
94	18000-A0712-0013	Muffler	1
95	18215-A0710-0001	Exhaust gasket	1
96	18172-A0710-0001	Fill valve gasket	1
97	T152-0033	Stud M6×22	2
98	T314-0001	Nut M6	2
99	18171-A0710-0001	Fill valve	1
100	T441-0001	Spring washer	2
101	16622-A0710-0002	Pipe clamp 8mm-10mm	3
102	16621-A0710-0020	Outlet pipe	1
103	T152-0011	Bolt M6×28	1
104	16630-A0710-0001	Connector	1
105	T311-0002	Nut M6	2
106	16610-A0710-0003	Filter cup	1
107	16400-A0410-0002	Fuel filler cap with packing ring	1
108	16510-A0712-0081	Fuel tank	1
109	16557-A0710-0001	Outlet connector	1
110	16622-A0710-0003	Pipe clamp 10mm-14mm	2
111	11513-A0710-0002	Snorkel	1
112	12158-A0710-0001	Lagging	1
113	55550-EEA10-0001	Wand assy	1
114	55100-EEA14-0001	Frame	1
115	55511-E8310-0001	High pressure pipe	1
116	45420-E8310-0001	Wheel	2
117	T315-0002	Nut (M12)	2
118	55600-EEA10-0001	High pressure pump assembly	1
119	55510-E8310-0001	Water Outlet Pipe Components	1
120	24100-A0714-0001	Starting motor Assy	1
121	T151-0008	Bolt, M8×35	2
122	24130-A0714-0001	Charge coil	1
123	24145-A0714-0001	Clamper, cord	1
124	T152-0019	Bolt M6×12	1
125	T152-0030	Bolt M6×30	2
126	31211-E8310-0003	Control panel	1
127	31225-B9140-0002	The ignition switch	1
128	32480-BB140-0002	Armrest latch assembly	2
129	55530-E8310-0003	Inlet pipe assembly	1

Electric Start Units

ELECTRIC DIAGRAM (for electric-start type)

Bl	Black	Gr	Grey
Y	Yellow	R	Red
W	White	G	Green

	IG	E	ST	BAT
OFF	○	○		
ON				
START			○	○

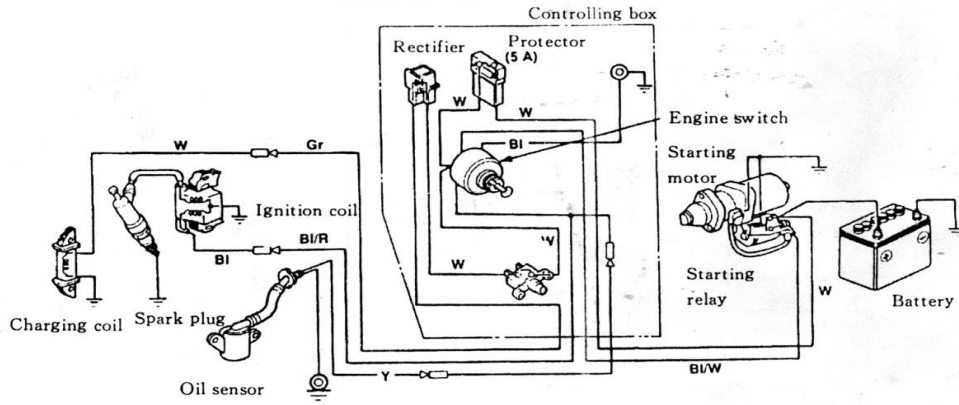

ELECTRIC DIAGRAM

Bl	Black
Y	Yellow
G	Green

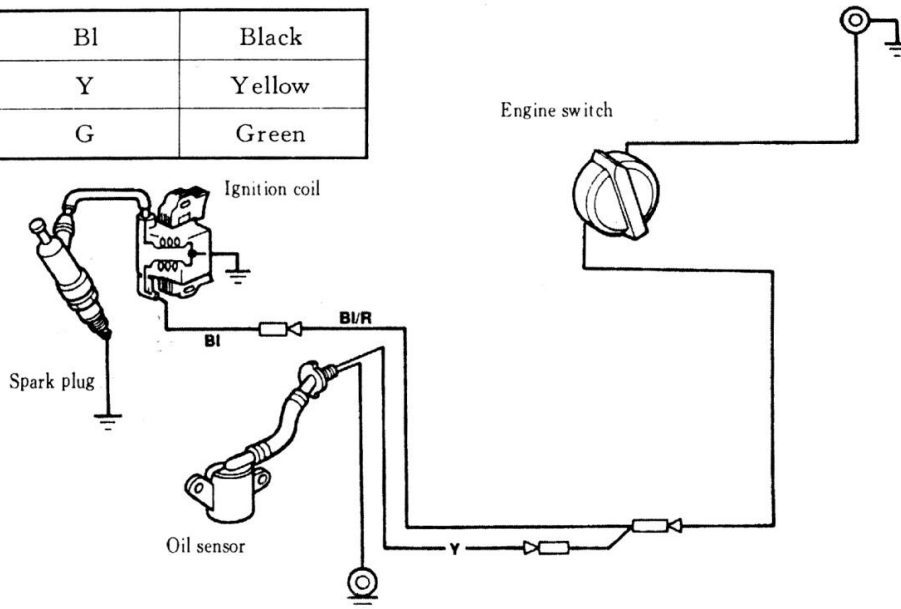

K-2052-1