

LIFAN

INVERTER GENERATOR Owner's Manual

KP4800iE

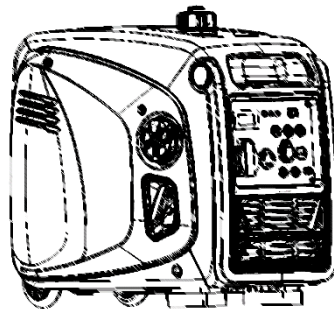

Read this manual carefully before operating this generator.

PREFACE

Thank you for choosing a gasoline generator set by our Co.

Based on the latest technology at home and abroad, our Co. has successfully developed the gasoline generator set. The unit is characterized by advanced design, compact structure, reliable performance, convenient service, low fuel consumption and noise as well as fashion shape. With general gasoline engine as power, it is widely used in many fields such as living, open working, shop, bank, fishing, etc.

The manual gives information with respect to operation and maintenance of the gasoline generator, and be sure to read it carefully first before operating. If any trouble occurs, call your dealer who will provide you with the best after service.

All the materials and diagrams of this manual are in accordance in this manual may be a little different from the actual states. The copyright of this manual belongs to our Co., any group or individual is forbidden to reprint or copy any of it. The manual is subject to change without notice.

Safety Warnings

Please read this manual carefully before using this gasoline generator set .

Special important contents in this manual will be indicated in the following ways, please note.

- : If you do not follow the instructions, your life will be in danger or you will be seriously injured.
- : If you do not follow the instructions, your life will be in danger or you will be seriously injured.
- : Failure to follow instructions may result in minimal harm.
- : Failure to follow instructions may result in damage to your engine set and other property.

This specification is a permanent part of the gasoline generator set and should be attached when the gasoline generator set is transferred to others.

CONTENTS

1. Safety notice for gasoline generator set	1
2. Introduction to Parts and Components	4
3. Control function	7
3.1 Three-in-one combination switch	7
3.2 Oil alarm indicator light (red)	10
3.3 Overload alarm indicator light (red)	10
3.4 AC indicator light (green)	11
3.5 DC protection	12
3.6 Energy-saving switch	13
3.7 Voltage recovery button	13
3.8 Fuel tank cap	13
3.9 Fuel tank cap vent knob	14
3.10 Grounding (Earth) terminal	14
3.11 Parallel operation	14
4. Pre-use inspection	15
4.1 Fuel	15
4.2 Engine oil	16
4.3 Preparation	17

5. The operating	18
5.1 Start	19
5.2 Stop	20
5.3 AC connection	21
5.4 Battery charging	22
5.5 AC parallel operation	24
5.6 Scope of application	26
6. Maintenance	28
6.1 Spark plug maintenance	30
6.2 Adjustment of carburetor	31
6.3 Replacement of engine oil	32
6.4 Air filter	33
6.5 Muffler mesh and spark collector	34
6.6 Fuel tank filter	35
6.7 Change of carburetor for highland	35
7. Storage	36
8. Troubleshooting	37
9. Parameters	38
10. Wiring diagram	40

1. Safety notice for gasoline generator set



1. Never operate it in an enclosed room.



2. Never connect to home circuit.



3. Do not operate it under wet circumstances.

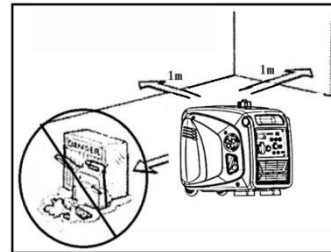

4. Keep the inflammables away from the unit at least one meter.



5. No smoking when filling fuel.



6. Always fill fuel after stopping it.



7. Do not spill out when filling fuel.

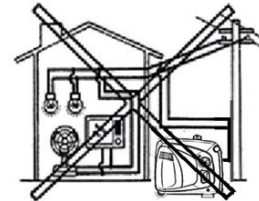

8. This product is AC power supply, do not connect with the mains, serious may cause explosion.



When connecting the generator to home power supply, make sure it's done by a skilled electrician.

Improper connecting between the generator and loads may cause damage, burn or fire to the generator.

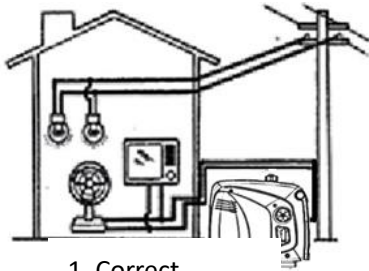

1. Correct

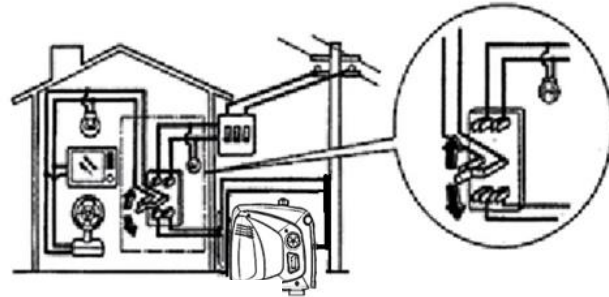

2. Correct

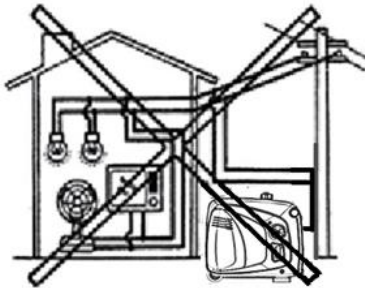

3. Forbidden

2.Introduction to Parts and Components

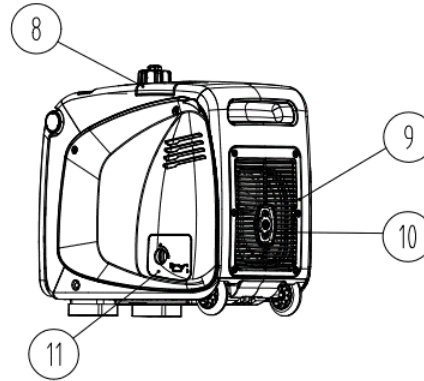
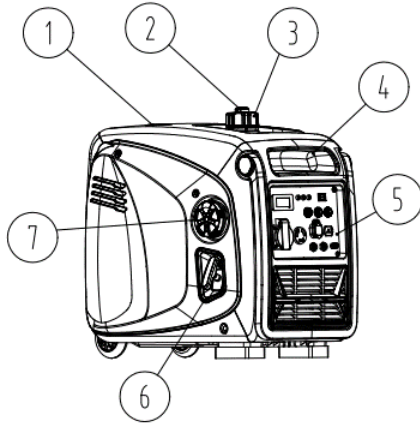

- ① Fuel level viewing window
- ② Fuel tank cap vent knob
- ③ Fuel tank lock
- ④ Handle part
- ⑤ Control Panel

- ⑥ Starting handle
- ⑦ 4-in-1 switch knob
- ⑧ Spark plug maintenance cover
- ⑨ Muffler tail cover
- ⑩ Muffler

2.1 Control panel 120V 60Hz

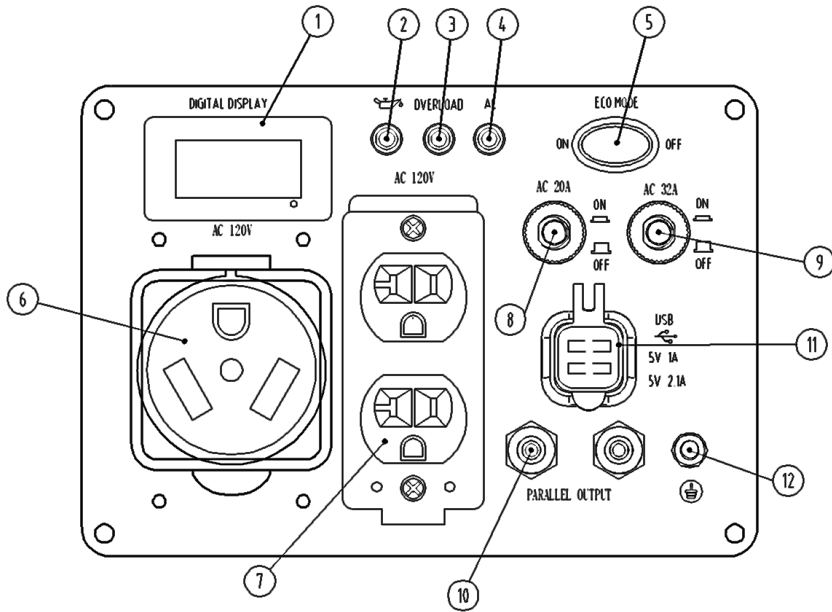

- ① Digital display
- ② Oil alarm indicator light (red)
- ③ Overload alarm indicator light (red)
- ④ AC indicator light (green)
- ⑤ Energy saving switch (ECO)
- ⑥ AC socket
- ⑦ AC socket
- ⑧ AC overheat protector
- ⑨ AC overheat protector
- ⑩ Parallel port
- ⑪ USB port
- ⑫ Grounding (earth) terminal

230V 50Hz

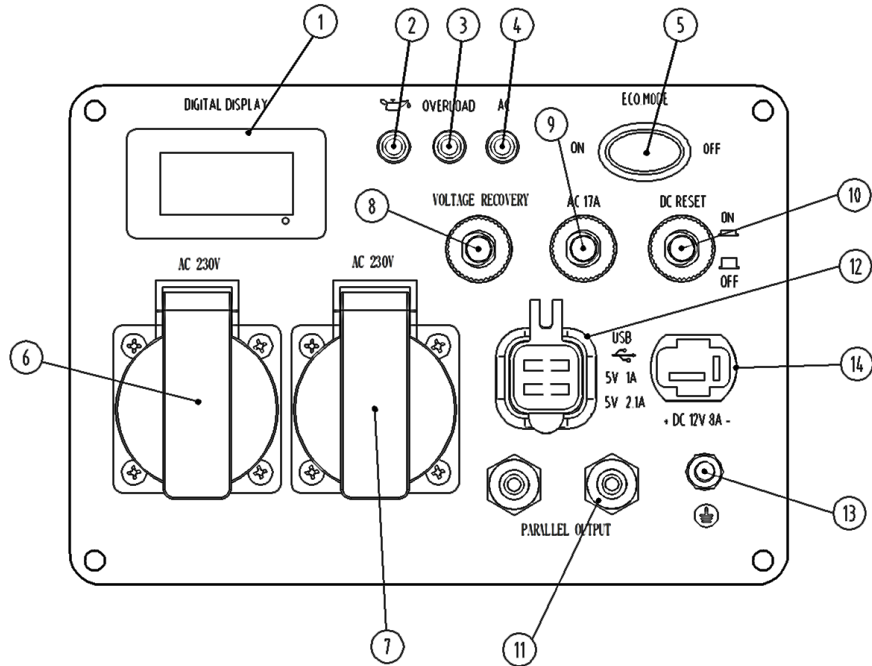

- ① Digital display
- ② Oil alarm indicator light (red)
- ③ Overload alarm indicator light (red)
- ④ AC indicator light (green)
- ⑤ Energy saving switch (ECO)
- ⑥ AC socket
- ⑦ AC socket
- ⑧ Voltage recovery button
- ⑨ AC overheat protector
- ⑩ DC reset
- ⑪ Parallel port
- ⑫ USB port
- ⑬ Grounding (earth) terminal
- ⑭ DC socket

3. Control function

3.1 4-in-1 Combination Switch (Regular Status)

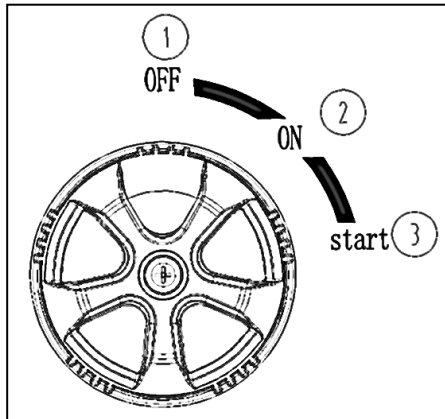

- ① engine and fuel switch "shutdown"; The ignition line is turned off, the fuel switch is turned off, and the engine will not ignite.
- ② Engine, fuel switch, choke switch "run"; The ignition line is in working condition, the fuel switch is on, the choke is fully open, and the engine can operate normally;
- ③ The engine, fuel switch and choke switch are "started", the ignition line is in working state, the fuel switch is open, and the choke door is closed; The engine can start normally.

Note: When the engine is warm-up, it does not need to be rotated to the "start" position when starting.

Tips: Please refer to 3.1.1 for the operation instructions of the one-button start unit

Please refer to 3.1.2 for instructions on the operation of LPG/NG dual-fuel units.

3.1.1 One-click start status

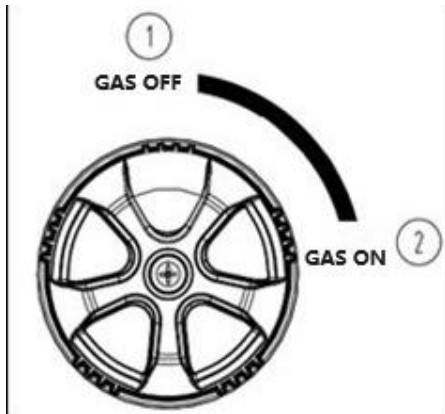

① The fuel switch is turned off, cutting off the engine fuel.

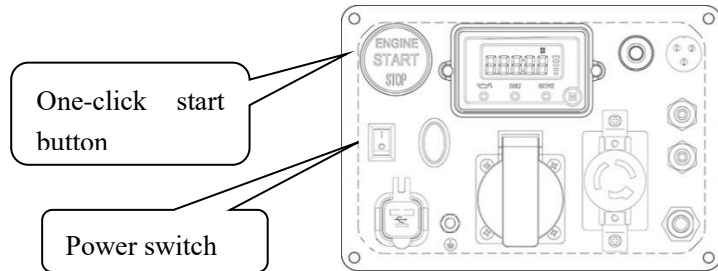

② The fuel switch is turned on, the power switch is turned on, and

the engine will start normally when the one-button start button is pressed.

Note: When the fuel switch is rotated to the “②” position, if it does not rotate to the specified position, insufficient fuel supply and abnormal operation of the engine will occur.

3. 1. 2 Dual-fuel status

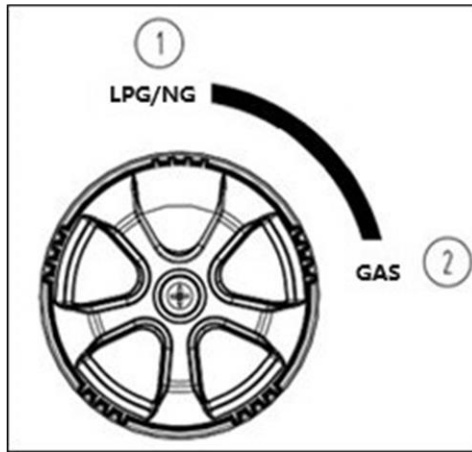

① The grid is on, the fuel is off.

One-click start button

Power switch

② Fuel on, grid/grid off.

③ After selecting the

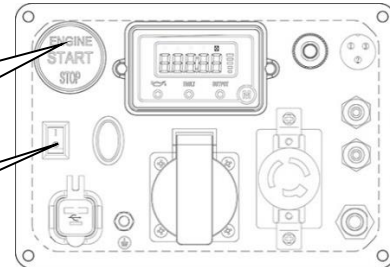

Corresponding fuel, turn on the power switch

Press the one-button start button and the engine will start normally.

Note: The dual-fuel switch is turned separately to “①、②” If the engine does not rotate to the specified position, the engine will start and run abnormally.

3.2 Oil alarm indicator (red)

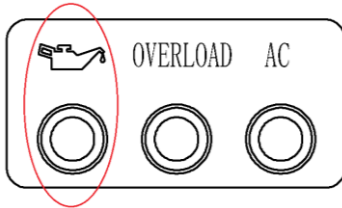

When lacking oil in crankcase, the oil protection system will automatically shut off the engine and the oil alarm indicator light will light up. Filling the oil to the oil level, the engine will start again.

NOTICE: If the engine fails to start, switch the engine switch knob to the "ON" position, then pull the start handle. If the oil alarm indicator light flashes for a few seconds, the oil is insufficient. Fill in the oil and restart.

3.3 Overload alarm indicator light (red)

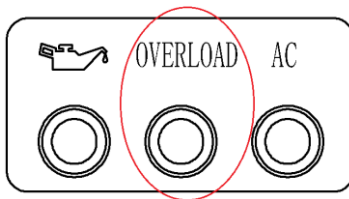

When the overload indicator lights up, it referred to the output of the connected loads has been overloaded, causing the inverter to overheat. At this time, the AC protector (circuit breaker) works and it makes the generator stop working to protect the generator and the connected electrical equipment. When the AC indicator light (green) is off and the overload indicator light (red) is on, the generator will not stop working.

When the overload indicator is on and the unit has no output, the following measures should be taken:

1. Close and remove the connected electrical equipment.
2. Reduce the total output of the connected electrical equipment to the rated output range.

3. Check whether there is a foreign body blocking the air inlet and whether there is any abnormality in the relevant control parts. If there is any problem, immediately eliminate it.

4. After check, press the voltage recovery button for 1-3 seconds to res the voltage output.

NOTICE: When using electrical equipment with high startup current (such as compressors, submersible pumps, etc.), the overload indicator may light up for a few seconds at the beginning. However, this may not be the fault mentioned above. Overload, short circuit, overheating and low engine speed, all of them can stop the output. Eliminate the above reason still the output is restored.

3.4AC indicator light(green)

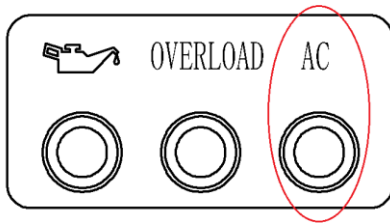

When the engine starts and outputs normally, the AC indicator lights up.

Indicator judgment:

1. Green light on: indicating normal operation, generator output;
2. Green light on and red light flashing: indicating overload, generator output;
3. When the green light is off and the red light flashes once every 3 seconds: indicating that the front-end voltage is too low and the generator has no output.
4. When the green light is off and the red light flashes twice in 3 seconds: indicating that the engine speed is too

low and the generator has no output.

5. When the green light is off and the red light flashes three times in three seconds: indicating that the temperature of the inverter is too high and the generator has no output.

6. When the green light is off and the red light flashes 5 times in 3 seconds: indicating that the bus voltage is too high and the generator has no output.

7. The green light is off and the red light flashes 6 times in 3 seconds: indicating overload protection and no output.

3.5DC protection

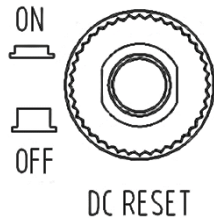

When the electronic equipment connected to the generator is running, if the rated current switch to the "ON" position if you want to operate the generator again.

"ON": Normal DC output

"OFF": No DC output.

NOTICE:

If DC reset button is off, reduce the load of the connected electronic equipment to the rated output range of the generator. If DC protection is still off, stop using electrical equipment directly and consult the dealer.

3.6 Energy-saving switch (ECO)

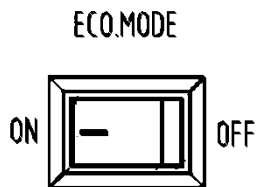

① "ON", when the energy saving switch is in the "ON" position, the generator is energy saving better, fuel consumption and lower noise.

② "OFF", when the energy saving switch is in the "OFF" position, the engine is running at the rated speed (4400r/min) regardless of whether the load is connected.

NOTICE: When using the following equipment, such as air compressor, sunk water pump, the energy-saving switch must be shut off due to the need for a large startup

current.

3.7 Voltage recovery button

VOLTAGE RECOVERY

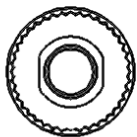

When the generator overload light is on, the generator has no voltage output, but will restore the voltage output.

NOTICE: When the overload voltage recovers, please ensure that there is no load connection, no short circuit and other faults before pressing the recovery voltage button.

3.8 Fuel tank cap

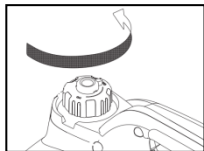

Rotate counterclockwise and remove the tank cap.

3.9 Fuel tank cap vent knob

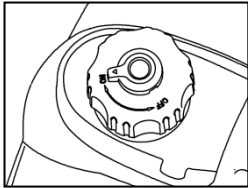

There is a vent knob on the top of the fuel tank to stop the flow of fuel. When using the generator, the vent knob must be in the "ON" position so that fuel can be injected into the carburetor to keep the engine running. When the generator is not in use, turn the ventilation knob to the "OFF" position to stop the flow of fuel.

3.10 Grounding (Earth) terminal

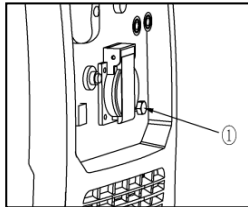

When connecting the grounding terminal to the grounding wire, be cautious of the electric shock. If the electrical equipment is grounded, the generator must be grounded.

3.11 Parallel operation

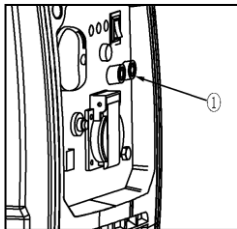

The parallel connector is used to connect two paralleling special cables of two same voltage and frequency devices of 4800i. Parallel operation requires two 4800i devices and special cables. (Rated output power of parallel operation is 5.7kW, rated current of 120V)

generator is 47.5A and rated current of 230V generator is 24.8A)

Operating procedures and related considerations are detailed in the parallel output system.

4. Pre-use inspection

NOTICE: Be sure to check before each use.

WARNING:

The engine and muffler will become very hot after it works. Do not check and repair them before they are cooling. Avoid any part of your body and clothes contact with the engine and muffler.

4.1 Fuel

DANGER: The fuel is a kind of flammable poison. Read carefully before refueling safety requirements (see page 2 for details). Don't fill up too much, or the tank will overflow when it warms up. After refueling, make sure the cap is screwed tightly.

NOTICE: After refueling, wipe the residual gasoline with a clean and soft cloth in time to avoid damage to the side plate. Unleaded gasoline must be used. Leaded gasoline can seriously damage engine internal parts.

Remove the fuel tank cap and add gasoline to the shoulder of the fuel filter.

- ① Red indicator bit;
- ② Fuel level.

Recommended fuel: unleaded gasoline
Fuel tank capacity: 10L (2.64 us gallons,
2.2 UK gallons)

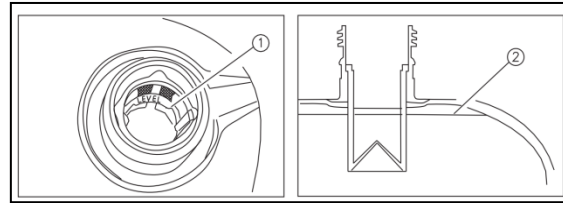

4.2 Engine oil

This generator is delivered without oil injection. Do not start the engine until sufficient oil has been injected.

1. Please place the engine on a horizontal ground.
2. Rotate the locking handle of the oil port baffle and remove the oil port guard①.
3. Turn on the dipstick③.
4. Inject the specified amount of recommended oil and tighten the dipstick②.
5. Install back the outer plate①.

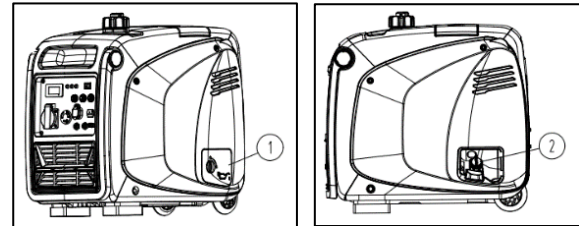

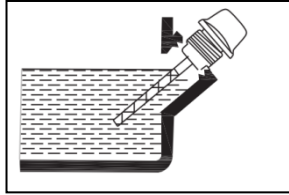

Recommended oil: SAE SJ 10w-40

Recommended oil grade: API standard SE or higher

Oil capacity: 0.5L

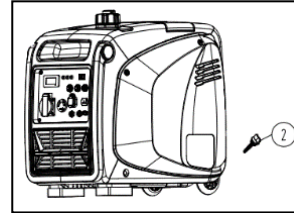

4.3 Preparation

WARNING: If any of the following parts do not work properly, please carefully check and repair the engine before starting.

The user should be concerned about the state of the generator. Even if the generator is not in use, its important parts may break down suddenly.

NOTICE: A pre-operation check should be made every time the generator is used.

Check before use:

Fuel (see P12)

- Check the fuel level in the fuel tank
- Refuel if necessary

Engine oil (see P13)

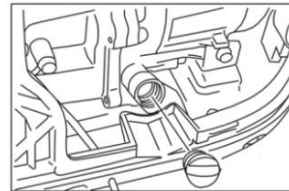

- Check generator oil level
- If necessary, add the recommended oil to the designated oil level
- Check for oil leaks

Abnormal conditions during operation

- Check running condition
- Consult the dealer if necessary

5.The operating

WARNING:

- Do not use the generator in a confined space. The gas discharged from the generator may cause loss of consciousness or even death in a short time. Please use it in a well-ventilated place.
- Do not connect any electrical equipment before starting the engine.
- To prevent electrical misuse, be sure to ground the gasoline generator set.

NOTICE: The generator is not filled with oil during transportation. Do not start the engine until sufficient oil is injected.

Do not tilt the engine when adding oil to prevent excessive oil from damaging the engine.

NOTICE: The generator can work with rated output load under standard atmospheric conditions.

- "Standard atmospheric conditions" : Ambient temperature: 25°C,

Atmospheric pressure: 100kPa, Relative humidity: 30%.

- The output of the generator will vary according to temperature, height (higher altitude, lower pressure) and humidity.
- When the temperature, humidity and height exceed the standard atmospheric conditions, the output of the generator will decrease.
- In addition, when used in small Spaces, the load must be reduced because the cooling of the generator will be affected.

5.1 Start

1. Turn the energy saving switch to "OFF".
2. Turn the fuel tank cap vent knob to "ON".
3. Turn the four-in-one switch to the position of "START" to:
 - A) turn the fuel on
 - B) turn the ignition system on
 - C) close the choke in a normal working state with cold engine
 - D) Press the power start button

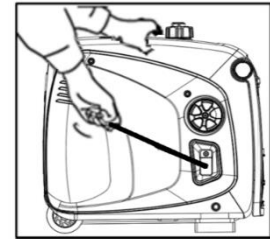
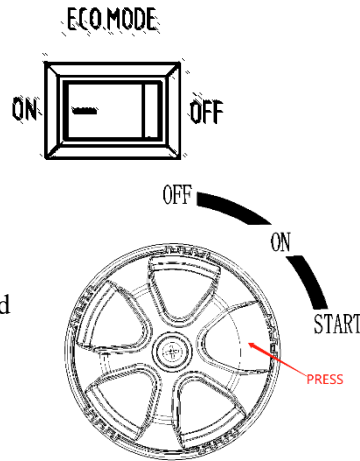
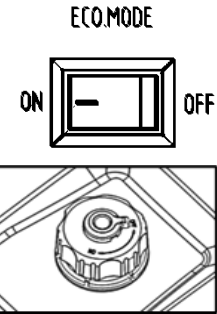

NOTICE: When the engine starts up, it is not necessary to close the choke and turn the three-in-one switch to the "ON" position

4. Gently pull the hand starter until the cable is hung and then pull it hard.

When the initiator is not in use, the electric start button can be directly pressed.

NOTICE: When pulling the hand starter, grasp the carrying handle to prevent the generator from falling down. When the engine is running smoothly after startup, turn the combination switch combination control handle to "ON".

NOTICE: Do not press the electric start button for more than 5 seconds, otherwise it will damage the starting motor, if several starts are unsuccessful, multiple starts should be 10 seconds apart. If the starting motor is used for a period of time, the speed drops a lot, which means that the battery is under voltage, and should be removed and charged.

5.2 Stop

NOTICE: Turn off all connected electrical equipment.

1. Turn the energy saving switch to "OFF"
2. Disconnect all electrical equipment



3. Rotate the combined switch to the "OFF" position to:

- A) turn the fuel off.
- B) turn the ignition system off.

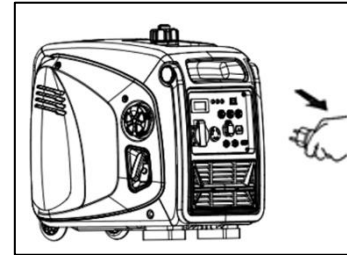

4. After the generator cools, turn the vent knob to "OFF"

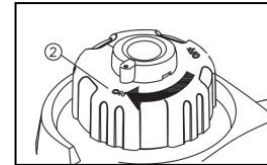
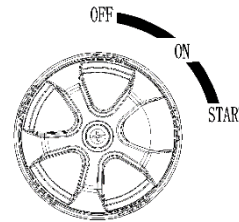

5.3AC connection

WARNING: All electrical equipment should be disconnected before the plug is inserted.

NOTICE:

- Ensure that all electrical equipment, including wires and plugs, are in good condition before connecting to the generator.
- Make sure all load of the generator is within the rated load range.
- Make sure the load current is within the rated current range of the rated socket.

NOTICE: Confirm that the unit is grounded. If the electrical equipment requires grounding, the unit must be grounded.

1. Start the engine
2. Turn the ESC energy-saving switch to "ON"
3. Insert the plug into the AC socket
4. Confirm that AC indicator is on
5. Turn on the electrical equipment

NOTICE: Before raising engine speed, ESC energy-saving switch must turn to "OFF".

If the unit provides power for multiple loads or electrical equipment, please start from high to low according to the load size of the electrical equipment.

5.4 Battery charging

NOTICE:

- The rated DC voltage of this generator is 12-14V
 - Connect the battery to the generator after the generator starts
 - Before starting charging, make sure the DC protector is on
1. Turn on the generator.
 2. Connect the charger red wire to the positive (+) battery terminal.
 3. Connect the black lead of the charger to the negative (-) terminal of the battery.

NOTICE:

- Make sure the charger red wire connected to the positive (+) battery terminal, black line and the cathode (-) terminals, not the reverse
- The charger cable is reliably connected to the end of the battery to prevent the generator from loosening under vibration or other conditions
- Follow the steps in the user manual to operate correctly
- During charging, if the current exceeds the rated current, the DC protector will turn off the output. Press the DC protector to the "ON" position to start charging again. If the DC protector is closed again, stop charging immediately and contact the dealer.

NOTICE:

- The following instructions in the user manual indicate the completion of charging.
- Measure the specific gravity or voltage of the electrolyte at about 13V to determine whether the battery is fully filled. At full charge, the electrolyte specific gravity is between 1.26 and 1.28.
- It is recommended to check the electrolyte specific gravity at least every 1 hour to prevent the battery from overcharging.

WARNING:

Do not smoke, connect or disconnect from the battery during charging. The resulting spark will ignite the gas around the battery.

Battery electrolyte contains sulfuric acid, which is toxic and a burn hazard. Avoid contact with skin, eyes and

clothes.

Treatment:

External contact -- wash with plenty of water

Ingest -- drink plenty of water or milk, milk containing magnesium oxide, eggs or vegetable oil. Call the hospital immediately

Eye penetrating --- rinse with water for 15 minutes, seek medical advice in time. Batteries can produce explosive gases. Keep away from sparks, flame, cigarette, etc. When using batteries in a confined space, please maintain ventilation. Close your eyes when working near the battery.

Keep the battery away from children.

5.5AC parallel operation

Before connecting a device to any generator, ensure that it is in good working condition and that its electrical rating does not exceed the total number of parallel generators. Most motors require more than their working current when started. When the motor is started, the overload indicator (red light) will go on. Normally, the overload indicator (red light) disappears within 4 seconds. If the overload indicator (red light) keeps on, consult your generator dealer.

When running in parallel, it is necessary to ensure that the voltage and frequency of the parallel generator are the same, and the ESC energy-saving switch of the two generators should be in the same position.

1. Provide the 4800i and another 4800i generator with its cable kit as instructed and connect the parallel operation cable.
2. Start the engine in turn to ensure that the output indicator (green light) of each generator is on.
3. Insert the device plug into the AC socket.
4. Turn on the device.

When the generator is overloaded or there is a short circuit in the connected equipment, the overload indicator (red light) will go on. The overload indicator (red light) will light up and keep on. After about 4 seconds, the connected circuit will stop, the output indicator (green light) will disappear, the generator and the device will stop working. Check and determine if it is caused by a short circuit or overload of the connected device. Correct the problem and restart the generator.

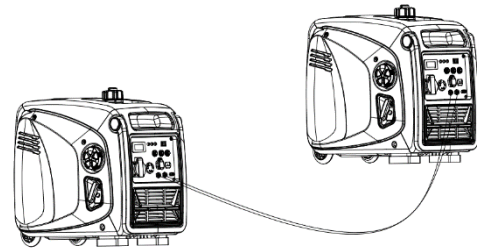

The two types of 4800i generators (same voltage and frequency) can be connected to each other, using a parallel cable suite to increase the available power supply.

Connect the equipment or power cord to the generator first as described in the accessories to the parallel running cable kit accessories.

NOTICE:

- Make sure it is in good working condition, a wrong device or power cord may cause an electric shock.
- If a device starts functioning abnormally, becomes sluggish, or stops suddenly, turn off the power

immediately, disconnect the device, and determine if the rated capacity of the appliance or generator has been exceeded.

- Ensure that the electrical rating of the combined tools or equipment does not exceed that of the generator. Do not exceed the maximum limit of 30 minutes.
- The variable frequency generator set with the same voltage and frequency can be connected in parallel when the load does not exceed the total output.
- In parallel operation, only the cable kit selected by our company can be run in parallel and then the 4800i is connected in parallel with another 4800i generator.
- Do not connect or unplug parallel operating cables while the generator is running.
- For single unit operation, the cable in parallel operation must be unplugged.

Warning: The overload indicator light (red) will keep on when a large amount of overload occurs, which may damage the generator. The overload indicator light (red) will flash when a light load overload occurs, which may shorten the service life of the generator.

The limit time when the maximum power can be operated: 30 minutes





Maximum power for parallel operation: 8.0kW

Rated power for parallel operation: 7.2kW, continuous operation, not exceeding rated power.

The requirement for total power of all connected equipment must be considered. The list of manufacturers of electrical appliances and power tools usually lists power ratings for similar models or serial numbers.

5.6 Scope of application

Before using the generator, make sure that the total load is within the rated load range of the generator, otherwise it may damage the generator.

AC				 DC
Power factor	1	0.8-0.95	0.4~0.75	
4800i	~3800W	~3040W	~1520W	Rated voltage: 12V Rated current: 8A

NOTICE:

- When each device works on its own, it will display the number of application power.
- AC and DC can be used at the same time and the single total power cannot exceed the rated output power.

For example:

Generator rated output		3800W
Frequently	Power factor	
AC	1.0	≤3800W
	0.8	≤3040W
DC	--	96W

When the total power exceeds the rated power, the overload indicator light will light up (see P8).

NOTICE:

Do not overload, the total power of the electrical equipment cannot exceed the output power of the generator, or it will damage the generator.

When using this generator to supply power to precision instruments, electronic controllers, personal computers, electronic computers, microcomputers, etc., please keep sufficient distance between the equipment and the generator to prevent electromagnetic interference of the engine. It also ensures that the engine is protected from the surrounding electronics.

If this generator is used to power medical equipment, it is recommended to consult the equipment manufacturer, professional or hospital about the amount of current required to start certain electronic equipment or General Motors, which may render them unusable. Even if its startup parameters meet the conditions in the above table, please contact the equipment manufacturer

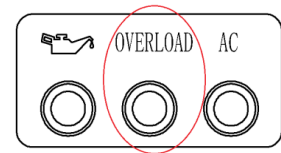

6. Maintenance

Good maintenance is the best guarantee to achieve safe, economical and zero fault operation. It also contributes to environmental protection.

The user should operate the machine safely. Periodic inspection, adjustment and lubrication can ensure safe and

efficient operation of the generator.

Warning: Please turn off the engine before maintenance.

Note: The original parts should be used in replacement. For more details, please contact the dealer.

Item	Routine	Pre-operation check (daily)	6 months or 100 Hr	12 months or 300 Hr
engine oil	Check the oil level	✓		
	Replace		✓ (*1)	
Fuel	Check	✓		
The fuel oil pipe	Check	✓		
Spark plug	Clean-adjust			✓★
Air filter	Check	✓		
	Clean		✓ (*2)	
Fuel tank filter	Clean or replace if necessary			✓
Valve clearance	Check-adjust			✓
Spark eliminator	Check-adjust		✓	
Cylinder head& piston	Clean carbon deposit			★★
★These items should be replaced if necessary				
★★These items shall be maintained by the company's authorized dealers, unless the user has appropriate tools and maintenance capabilities				

NOTICE:

*1-- the first oil change should be done one month before or 20 hours after operation

*2-- air filters should be cleaned more frequently when used in damp or dusty places

- If working under high temperature or load frequently, oil should be changed every 25 hours.
- If working frequently in dusty or harsh conditions, the air filter element should be cleaned every 10 hours and replaced every 25 hours if necessary.
- The inspection period and time should be the current maintenance.
- If the maintenance cycle time has passed, should be implemented as soon as possible according to the above table maintenance.

Warning:

Please stop the engine before any maintenance. The engine should be placed in a horizontal position and the spark plug cap should be separated from the spark plug to prevent engine from starting.

Do not use it indoors or in places with poor ventilation such as tunnels and caves. Make sure that the working area is well ventilated. Exhaust fumes from engines contain toxic gas carbon monoxide, which can cause shock, unconsciousness and even death when inhaled.

6.1 Spark plug maintenance

Spark plug is an important part of generator and must be checked regularly

1. Take off the outer protective plate and spark plug cover①, remove the spark plug cap②, and insert the sleeve④ into the hole from the outside of the cover;
2. Insert the screwdriver③ into the sleeve ④ and remove the spark plug by rotating counterclockwise;

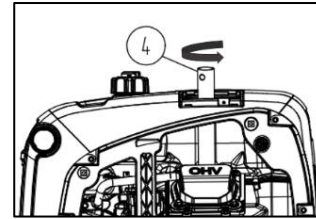
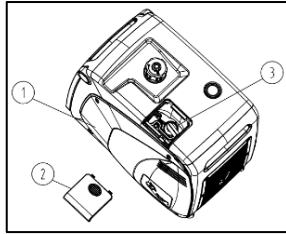

3. Check whether the color is faded and remove carbon deposit. The porcelain core around the central electrode of spark plug should be moderately light brown;
4. Check spark plug type and clearance;

Standard spark plug: F7RTC
 Spark plug gap: 0.7-0.8mm

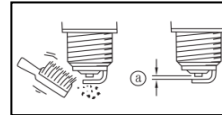

Tip: spark plug gap should be measured with a feeler or thickness gauge, and adjusted if necessary.

5. Install spark plug; 6. Install spark plug cap and cover.

Tip: When installing spark plug without a torque wrench, a better estimation method is to twist 1/4 to 1/2 turns by hand. However, the spark plug should be tightened as soon as possible to the specified torque.

6.2 Adjustment of carburetor

Carburetor is an important part of engine. It should be adjusted by the dealer with professional knowledge and equipment to ensure

Torque : 20-25 N • m

proper adjustment.

6.3 Replacement of engine oil

Warning: do not drain oil immediately after shutting down the generator. Oil temperature is still very high, operation should be careful to avoid burns.

1. Place the generator on a level plane and start the generator for a few minutes to increase its temperature before stopping

the engine. Turn the three-in-one combination control knob and

fuel tank cover ventilation knob to “OFF” state.

2. Rotate the locking handle of the oil port baffle and remove the oil port guard①
3. Remove the oil cap②
4. Place the oil pan under the engine, tilt the generator, pour the oil out quickly.
5. Place the generator on a level plane again.
6. Refill the oil into place.
7. Clean the cap and wipe off the splashed oil.
8. Tighten up the oil scale.

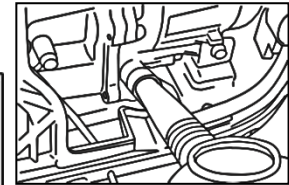
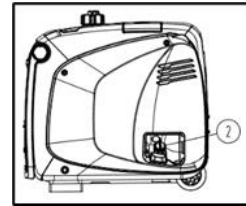
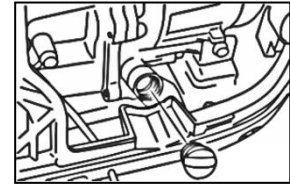
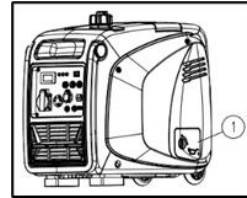

Engine oil: SAE 10W-40

Engine oil: API standard SE or higher

Cubage: 0.5L

9. Cover the outer plate .

Note: Do not tilt the engine when adding oil to prevent excessive oil from damaging the power.

Do not let foreign matter into engine case.

6.4 Air filter

1. Remove the screw①, and outer plate②.
2. Remove the screw③, and air filter cover④.
3. Remove the foam element⑤.
4. Clean the foam element with solvent and dry it.
5. Add oil to the foam element and squeeze out the excess oil.

The

foam element should be wet, but it shouldn't drip oil.

Note: Do not twist the foam element to avoid damage.

6.Place the foam element in the air filter.

Tip: Make sure that surface of foam element is close to the air filter without gap. Do not start the engine when the filter is not in place, as excess gas and cylinder wear may occur.

7. Return the air filter cover to the original position and tighten the screw.

8. Put back the outer cover plate and tighten the screw.

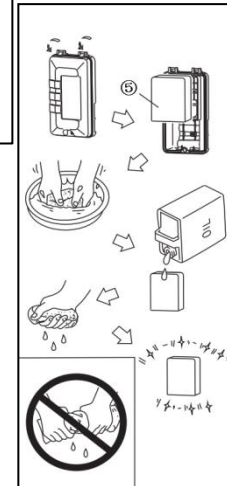
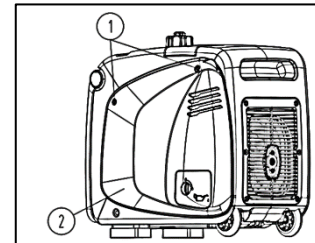
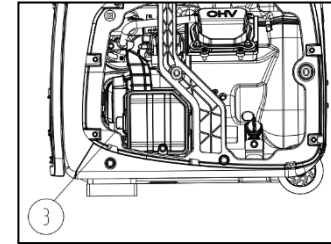

6.5 Muffler mesh and spark collector

Warning: engine and muffler may become very hot after engine operation. Do not allow your skin and clothing to directly touch the engine and muffler during inspection and maintenance.

1. Remove the screw①, remove the rear blinds②.
2. Remove the screw③, remove the muffler hat④, muffler mesh⑤ and spark collector⑥.

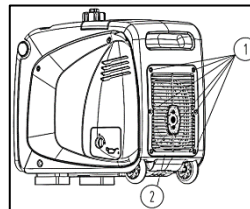

3. Use wire brush to deposit carbon on muffler mesh cover and spark collector.

Note: clean with steel wire gently to avoid damage or scratch the muffler mesh and spark collector.

4. Check the muffler mesh and spark collector, replace them immediately if they are damaged.

5. Reinstall the spark collector.

Note: To ensure the spark collector's protrusion point⑦and small hole of muffler pipe⑧ are on a straight line.

6. Put the muffler mesh cover and muffler cap back.

7. Put back the rear blinds and tighten the screw.

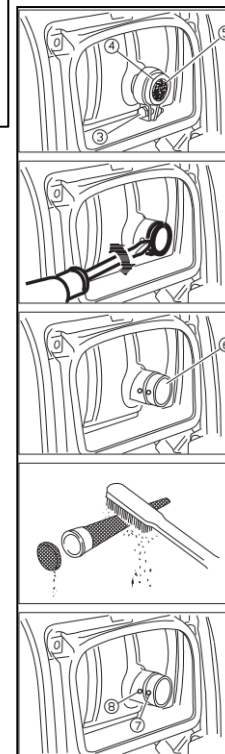

6.6 Fuel tank filter

Warning: Do not use gasoline where there is smoke or flame.

1. Remove fuel tank cap and filter.
2. Clean the fuel tank filter with gasoline.
3. Dry the strainer and put it back in the fuel tank.
4. Put the fuel tank cap back.

NOTE: Screw the cover rightly.

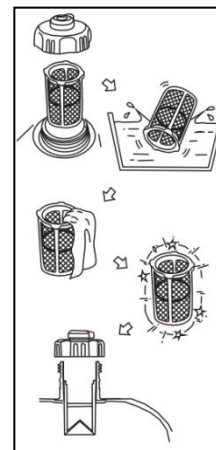

6.7 Change of carburetor for highland

At high altitude area, intake air amount of standard carburetor will be decreased due to air pressure, that results in the drop performance and increased fuel consumption. Rich mixture also will contaminate the spark plug to cause difficulty in starting. Exhaust emission may be increased when the engine is operated at a altitude differ from the engine is certified.

If your engine always work at an high altitude ($\geq 1500\text{m}$), please contact your dealer to modify the carburetor to improve the engine performance. In this case, the modified carburetor will meet all emission standard during its service life.

7.Storage

Some storage measures should be taken to prevent aging if you plan to store this generator for a long time.

7.1Draining off fuel

1. Turn OFF the four-in-one combination switch knob.
2. Open the tank cap and remove the filter. Take all the fuel from the tank into the special tank and reinstall the tank cap.

Warning: The fuel tank is highly volatile and toxic. Please read the safety instructions carefully (see page 1).

Note: Clean and soft cloth should be used in time to wipe away the spilled oil. Prevent damage to plastic case.

- 3.Start the engine (see page 18) and shut down it until fuel in is exhausted after about 20 minutes.

- Do not connect any electrical equipment
- Running time of engine depends on the fuel remaining in the tank

4. Remove the screw and outer cover plate.
5. Loosen the drain bolt on the carburetor and put the fuel in the carburetor into the special tank.
6. Turn the three-in-one control switch to the “CHOKE”.
7. Tighten the drain bolt.
8. Put back the cover plate and tighten the screw.
9. After the engine has cooled completely, close the vent knob on the tank cover.

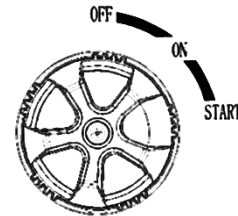

7.2 Engine storage

Follow the steps below to protect the box, piston ring and other corrosion-prone parts.

1. Remove the spark plug, pour in a spoonful of SAE10W40 oil, install the spark plug, and pull the hand-pull starter (close the combination switch) for a few minutes to lubricate the cylinder block with the oil.
2. Pull the hand-operated starter until you feel the tension (prevent the cylinder body and valve from rusting).
3. Clean the surface, and put the engine in a ventilated and dry place, and cover it with a sheath.

8 Troubleshooting

Engine can't start

1. Fuel system

There is no gasoline in the combustion chamber

No fuel in the tank... Refuel

There's oil in the tank... Verify that the vent knob is open;

Clogged fuel filter... Clean fuel filter;

Carburetor is blocking... Clean carburetor;

2. Oil system

insufficient

Oil level is too low... Filling the oil

3. Electrical system

Combination switch to "CHOKE", hand starter normal... Spark plug can't ignite

Spark plug has carbon deposits or moisture... Clean and dry spark plug

Trouble in ignition system... Please contact your dealer

The generator has no voltage output

Safety device (DC protector) in "OFF" position...

Press the DC protector to be in the "ON" position.

AC indicator light (green) off... Stop the engine and

restart. Or press the voltage recovery button for 1-3 | seconds to restore the voltage output.

9Parameters

	Model No.	KP4800iE
Generator	Type	Inverter
	Rated frequency/Hz	50/60
	Rated voltage/V	110/120/220/230/240
	Rated output power/kW	3.8
	Max. output power / kW	4.0
	Power factor	1
	DC output /V-A	12V-8A
	AC output quality	ISO8528 G2
	THD/%	3
	Noise /dB	61~70

	Overload protect	DC	Non-fuse protector
		AC	Controlled by inverter overload protect program
Engine	Engine model		170F-3
	Engine type		Single cylinder,4-stroke,forced air cooling, OHV
	Displacement/cc		192
	Fuel type		Unleaded gasoline
	Fuel tank capacity/L		10
	Continue running time/h		8
Engine	Engine oil capacity		500ml
	Spark model No.		F7RTC
	Starting mode		By hand/Electrical start
Generator set	L×W×H/mm		540*340*510
Net weight/Kg			30

10Wiring diagram

AC 120V 60Hz

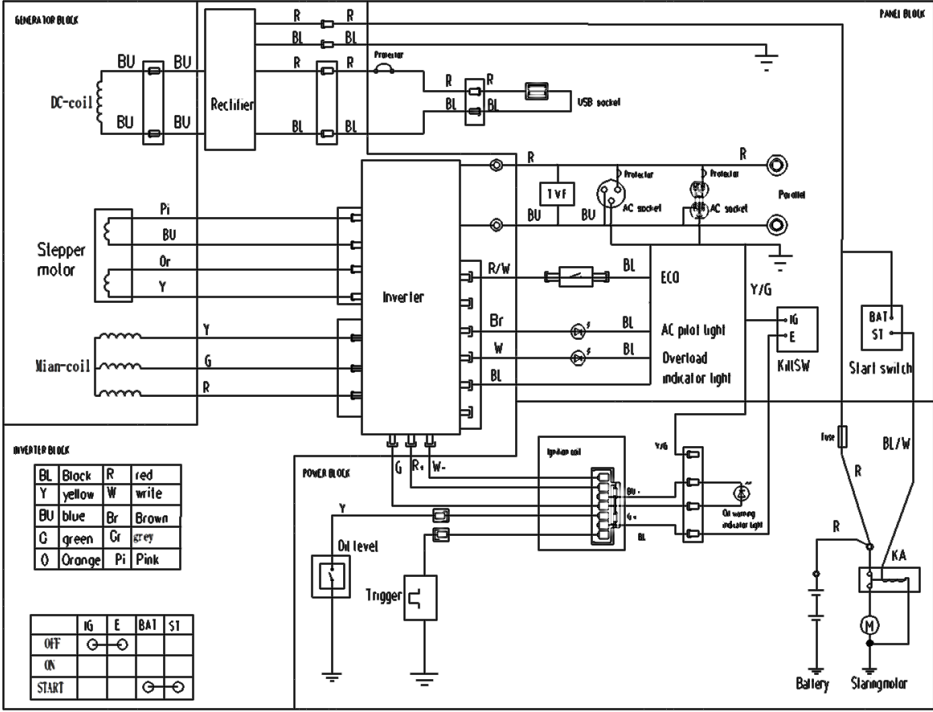

AC 230V 50Hz

