

### 3. DIMENSIONAL DRAWINGS

[1] [ ]: Fuel tank protector equipped types [2] Unit: mm (in)

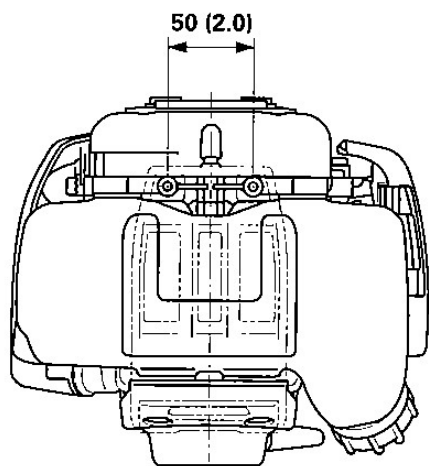
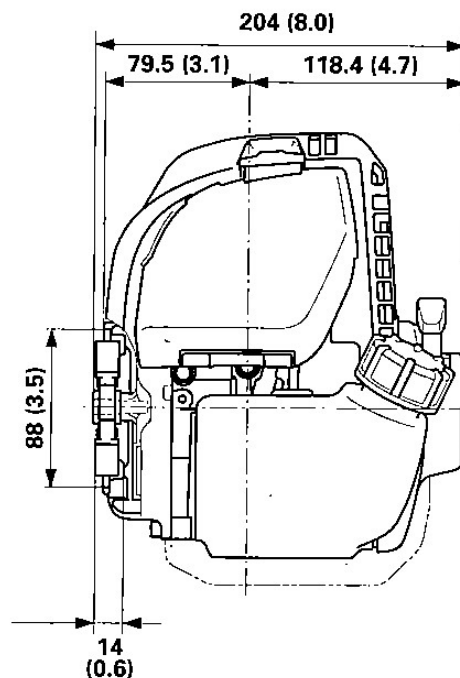
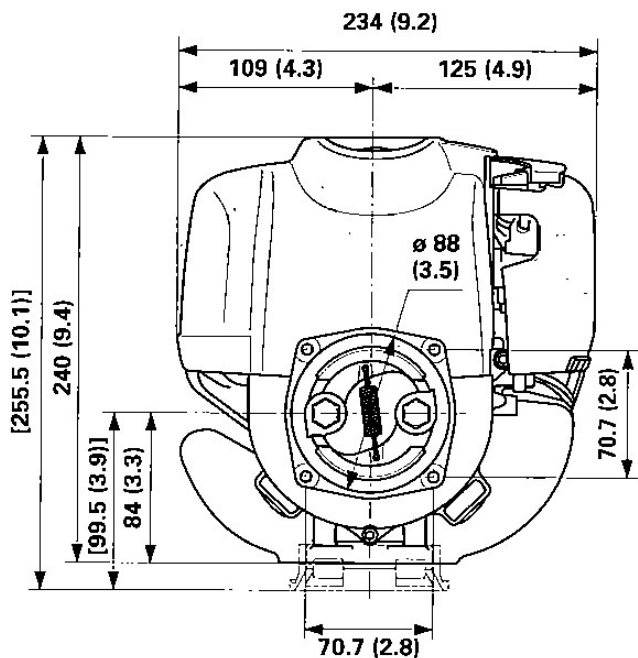

#### 3. PLANS COTES

[1] [ ]: Types avec protecteur de réservoir de carburant  
[2] Unité: mm

#### 3. MASSZEICHNUNGEN

[1] [ ]: Typen mit Kraftstofftankschutz  
[2] Einheit: mm

#### 3. PLANOS DE DIMENSIONES

[1] [ ]: Tipos equipados con protector del depósito de combustible  
[2] Unidad: mm