

# INVERTER PETROL GENERATOR

## Owner's Manual

### KP3500iO-2

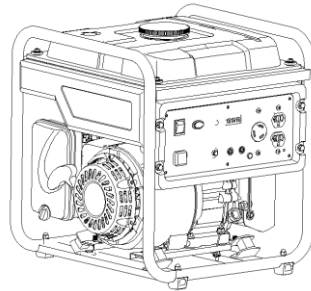

Read this manual carefully before operating this generator

## **PREFACE**

Thank you for choosing a petrol generator from our Company

Based on the latest technology at home and abroad, our Company has successfully developed the petrol generator. The unit is characterised by advanced design, compact structure, reliable performance, convenient service, low fuel consumption and noise as well as fashionable shape. With a stationary petrol engine as power, it is widely used in many fields such as living, outdoor working, shop, camping, fishing, etc.

This manual provides information with respect to operation and maintenance of the petrol generator. Please read it carefully first before operating. If any problems occur, call your dealer who will provide you with the best after service.

All the materials and diagrams of this manual may differ slightly from the actual products. The copyright of this manual belongs to our Company; any group or individual is forbidden to reprint or make copies. The manual is subject to change without notice.

## Safety Warnings

Please read this manual carefully before using this petrol generator set 

Special important contents in this manual will be indicated in the following ways, please note:

**DANGER:** If you do not follow the instructions, your life will be in danger or you will be seriously injured

**WARNING:** If you do not follow the instructions, your life will be in danger or you will be seriously injured

**CAUTION:** Failure to follow instructions may result in minimal harm

**NOTICE:** Failure to follow instructions may result in damage to your engine set and other property

This specification is a permanent part of the petrol generator set and should be attached when the petrol generator set is transferred to others

# CONTENTS

|   |    |
|---|----|
| 1. Safety notice for petrol generator .....   | 1  |
| 2. Introduction to Parts and Components ..... | 4  |
| 3. Control functions .....                    | 6  |
| 3.1 Stopping the Engine .....                 | 6  |
| 3.2 Low oil warning light (red) .....         | 6  |
| 3.3 Overload indicator light (red) .....      | 7  |
| 3.4 AC indicator light (green) .....          | 8  |
| 3.5 DC protection .....                       | 9  |
| 3.6 Energy conservation switch .....          | 9  |
| 3.7 Voltage recovery button .....             | 10 |
| 3.8 Fuel tank cap .....                       | 10 |
| 3.9 Grounding (Earth) terminal .....          | 11 |
| 3.10 Parallel operation .....                 | 11 |
| 4. Pre-use inspection .....                   | 12 |
| 4.1 Fuel .....                                | 12 |
| 4.2 Engine oil .....                          | 13 |
| 4.3 Preparation .....                         | 14 |

|                                      |    |
|--------------------------------------|----|
| 5. Operating                         | 15 |
| 5.1 Starting the Generator           | 16 |
| 5.2 Stopping the Generator           | 17 |
| 5.3 AC connection                    | 18 |
| 5.4 AC parallel operation            | 19 |
| 5.5 Scope of application             | 21 |
| 6. Maintenance                       | 23 |
| 6.1 Spark plug maintenance           | 25 |
| 6.2 Engine Oil Replacement           | 26 |
| 6.3 Carburettor adjustment           | 27 |
| 6.4 Air filter                       | 27 |
| 6.5 Muffler mesh and spark collector | 28 |
| 6.6 Fuel tank filter                 | 29 |
| 7. Storage                           | 29 |
| 7.1 Removing the Fuel                | 29 |
| 7.2 Engine Storage                   | 30 |
| 8. Troubleshooting                   | 31 |
| 9. Parameters                        | 32 |
| 10. Wiring diagram                   | 34 |

# 1.0 Safety Notice for Petrol Generator



1. Never operate in an enclosed room



2. Never connect directly to home/mains electricity



3. Do not operate in wet conditions

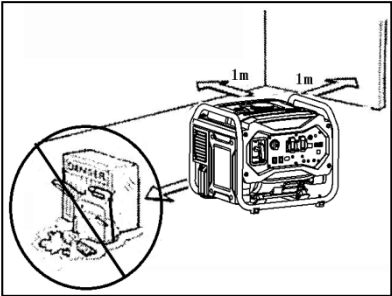

4. Keep inflammables at least 1m away from the unit



5. No smoking when filling fuel

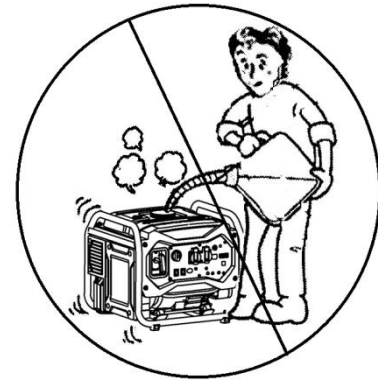

6. Stop the generator before refueling



7. Avoid spilling fuel when filling

**⚠ DANGER**

If connecting the generator to home/mains power supply, ensure this is performed by a qualified electrical engineer as this involves fitting specialist switch gear (ATS). Improper connection between the generator and loads could cause injury, death, fire and damage to the generator

1. Correct

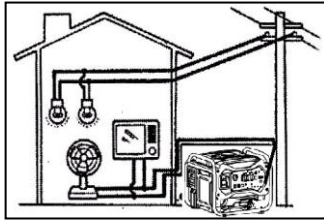

2. Correct

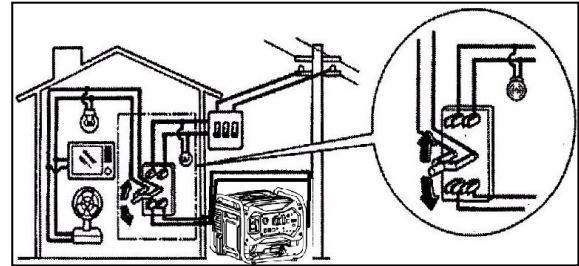

3. Incorrect/dangerous

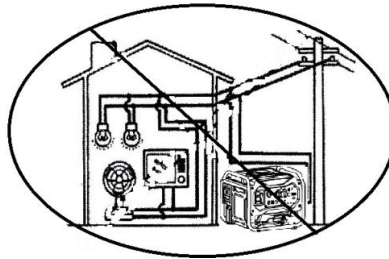

## 2.0 Introduction to Parts and Components

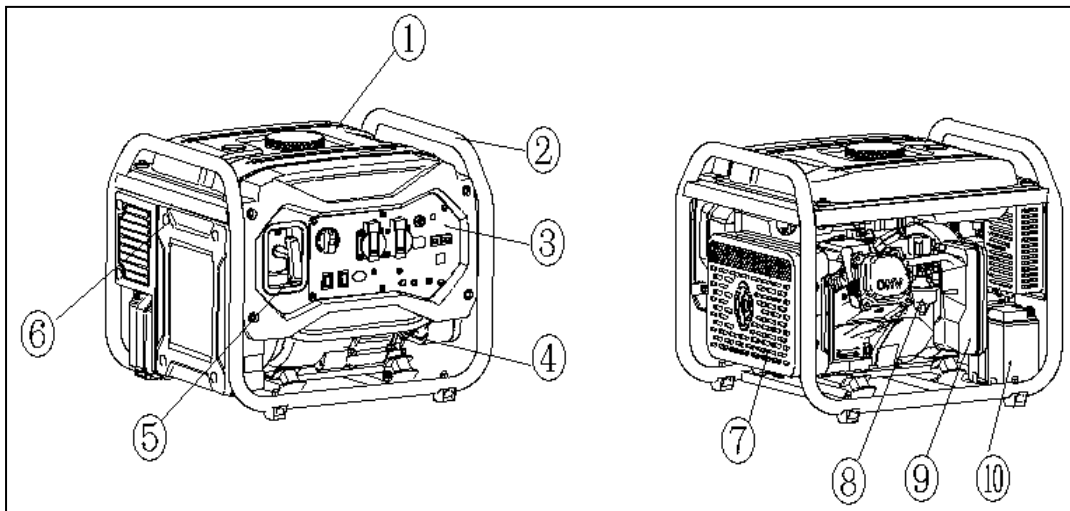

- ① Fuel tank
- ② Frame
- ③ Control panel
- ④ Oil Filler Cap/dipstick
- ⑤ Starting handle

- ⑥ Inverter housing
- ⑦ Muffler assembly
- ⑧ Carburettor
- ⑨ Air filter housing
- ⑩ Battery

## 2.1 Control panel

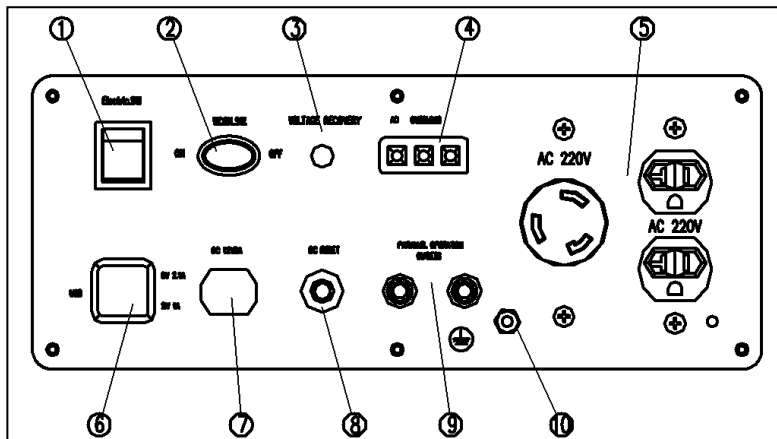

① On/Off Rocker Switch

② Energy Conservation Switch (ECS)

③ Voltage recovery button

④ Indicator lights

⑤ AC socket

⑥ USB socket

⑦ DC socket

⑧ DC protection

⑨ Parallel socket

⑩ GND

### 3.0 Control function

#### 3.1 On/Off Rocker Switch

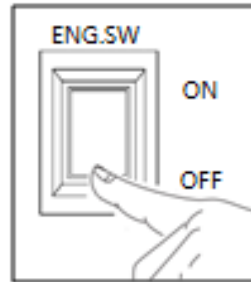

#### 3.2 Low Oil warning light (red)

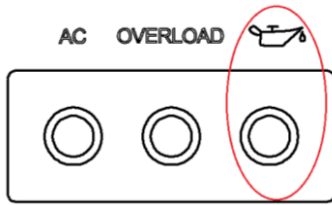

When the crankcase oil drops below the safety level, the oil protection system will automatically shut off the engine, and the low oil warning light (red) will light up; Filling the oil to the oil, the engine will allow the engine to be restarted

**NOTICE:** If the engine stalls or fails to start, rotate the power switch knob to the "running" position, then pull the start handle. If the low oil warning light (red) flashes for a few seconds, the oil is insufficient. Fill in the oil and restart.

### 3.3 Overload indicator light (red)

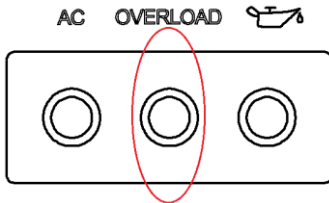

When the overload indicator lights up, it has detected that the output of the connected equipment has overloaded, causing the inverter to overheat or AC voltage to rise. The AC protector will kick-in and prevent the generator from working to protect the generator and the connected electrical equipment. When the AC indicator light (green) is off and the overload indicator light (red) is on, the generator will not stop working.

When the overload indicator is on and the unit has no output, the following measures should be taken:

1. Close and remove the connected electrical equipment.
2. Reduce the total power of the connected electrical equipment to the rated output range.
3. Check whether there is a foreign body blocking the air inlet and whether there is any abnormality in the relevant control parts. If there is any problem, immediately eliminate it.
- 4: After checking, press the voltage recovery button for 1-3 seconds to restore the voltage output.

**NOTICE:** When using electrical equipment with high startup current (such as compressors, submersible pumps, etc.), the overload indicator may light up for a few seconds at the beginning, however, this may not necessarily be the fault mentioned above. Overload, short circuit, overheating and low engine speed can all prevent output. Eliminate the above reasons until the output is restored.

### 3.4 AC indicator light (green)

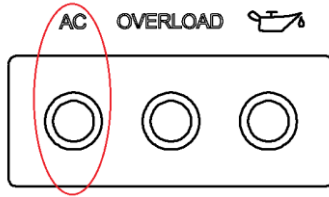

When the engine starts and outputs normally, the AC indicator lights up.

Indicator judgment:

1. Green light: indicates normal operation, generator output;
2. Green light, red light flashing: indicates overload, generator output;
3. When the green light is off, the red light flashes once every 3 seconds, this

indicates that the bus front-end voltage is too low and the generator has no output.

4. When the green light is off and the red light flashes twice in 3 seconds, this indicates the engine speed is too low and the generator has no output.

5. When the green light is off and the red light flashes three times in three seconds, this indicates that the temperature of the inverter is too high and the generator has no output.

6. When the green light is off, the red light flashes 5 times in 3 seconds, this indicates that the bus voltage is too high and the generator has no output.

7. When the green light is off and the red light flashes 6 times in 3 seconds, this indicates overload protection and no output.

### 3.5 DC protection

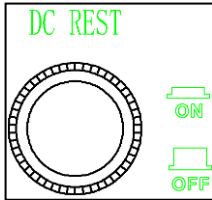

When the electronic equipment connected to the generator is running, if the rated current is exceeded, the DC switch will automatically turn to the “OFF” position. Press the DC switch to the “ON” position to operate the generator again.

“ON” = Normal DC output;

“OFF” = No DC output.

**NOTICE:** If DC protection is off, reduce the load of the connected electronic equipment to the rated output range of the generator. If DC protection remains off, stop using electrical equipment directly and consult the dealer.

### 3.6 Energy Conservation Switch

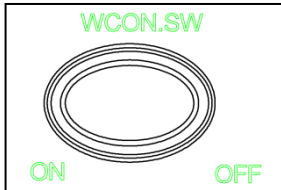

① "ON", when the energy conservation switch is in the "ON" position, the energy saving device controls the engine throttle according to the connected load, which can achieve better fuel consumption and lower noise.

② "OFF", when the energy conservation switch is in the "OFF" position, the engine is running at the rated speed (3600r/min) regardless of whether the load is connected.

**NOTICE:** when using the following equipment, such as air compressor, submersible water pump, the energy-saving switch must be shut off due to the need for a large startup current.

### 3.7 Voltage recovery button

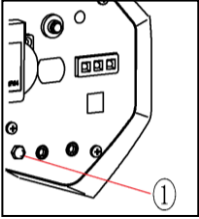

When the generator overload light is on, the generator has no voltage output, but still running, check and remove all the loads and press the voltage recovery button for 1-3 seconds to restore the voltage output.

**NOTICE:** When the overload voltage recovers, please ensure that there is no load connection, no short circuit or other faults before pressing the recovery voltage button.

### 3.8 Fuel tank cap

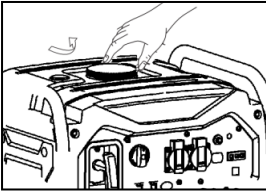

Rotate counter clockwise to remove the tank cap.

### 3.9 Grounding (Earth) terminal

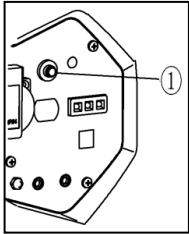

When the earth terminal is connected to the earth wire, electric shock is prevented.  
When electrical equipment is grounded, the generator must also be grounded.

### 3.10 Parallel Running

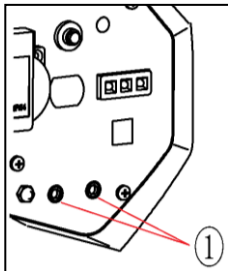

The parallel connector is used to connect two LF3500iO of the same voltage and frequency running parallel to one another. Parallel operation requires two LF3500iO devices and special cables. (rated output power of parallel operation is 6KVA, rated current of 120V generator is 25.0a, rated current of 230V generator is 13A)  
Operating procedures and related considerations are detailed in the parallel output system.

## 4.0 Pre-use inspection

**NOTICE:** Be sure to check before each use.

**WARNING:**

The engine and muffler will become very hot during use. Do not check or perform any repairs until they have fully cooled. Ensure any parts of the body or clothing do not come into contact with the engine and muffler.

### 4.1 Fuel

**DANGER:** Fuel is flammable and contains poisonous substances. Read the Safety Requirements carefully before refueling (see page 2 for details). Do not overfill with fuel or the tank will overflow once warm. After refueling, make sure the cap is screwed tightly.

**NOTICE:** After refueling, wipe any spilled fuel with a clean, soft cloth immediately to avoid damage to the plastic casing. Use unleaded petrol. Leaded fuel can seriously damage engine internal parts.

Remove the fuel tank cap and add petrol to the shoulder of the fuel filter.

- ① Red tab/level indicator
- ② Fuel level

Recommended fuel: unleaded petrol  
Fuel tank capacity: 10L (2.20 UK gallons)

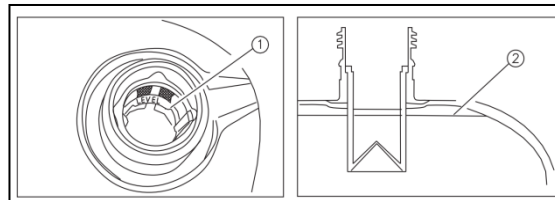

## 4.2 Engine oil

This generator is delivered without oil or fuel. Do not start the engine until the oil has been filled to the correct level

**NOTICE:** always check the generator on a level surface when switched off

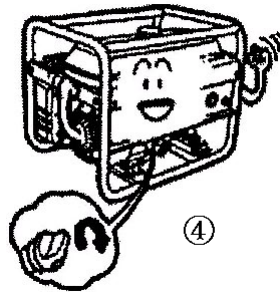
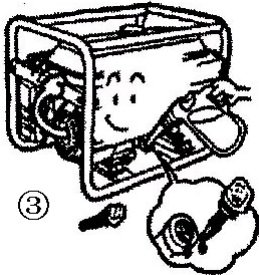
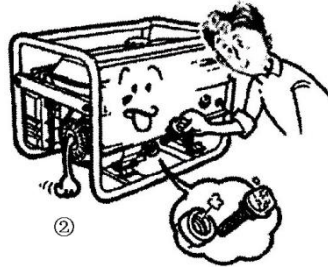
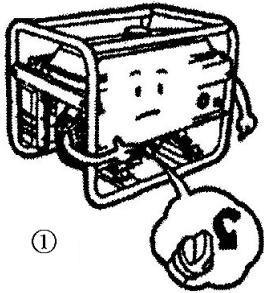

1. Remove the oil filler cap, wipe the dipstick with a clean cloth
2. Insert the dipstick into the oil port but do not tighten, remove the dipstick to check the oil level;
3. If the oil level is lower than the lower limit indicated on the dipstick, fill with fresh oil until the correct level is reached
4. Replace and tighten the oil filler cap.

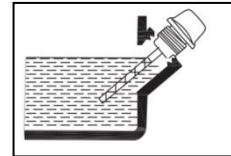

Recommended oil: SAE SJ 10w-30  
Recommended oil grade: API standard  
SE or higher  
Oil capacity: 0.6l

### 4.3 Preparation

**WARNING:** If any of the following parts do not work properly, please carefully check and repair the engine before starting.

The user should be concerned about the state of the generator. Even if the generator is not in use, its important parts may break down suddenly.

**NOTICE:** A pre-operation check should be made every time the generator is used.

Check before use:

Fuel (see P12)

- Check the fuel level in the fuel tank
- Add fuel if necessary

Oil (see P13)

- Check generator oil level
- If necessary, add the recommended oil to the designated oil level
- Check for oil leaks

Abnormal conditions during operation

- Check running condition
- Consult the dealer if necessary

## 5.0 Operating the Generator

### **WARNING:**

- Do not use the generator in a confined space. The exhaust gasses discharged from the generator may cause loss of consciousness or even death in a short time. Please use it in a well-ventilated place.
- Do not connect any electrical equipment before starting the engine.
- To prevent electrical misuse, be sure to ground the petrol generator.

**NOTICE:** The generator is not filled with oil during transportation. Do not start the engine until the generator has been filled with the correct grade and amount of oil.

Do not tilt the engine when adding oil to prevent over/under filling and causing damage to the engine.

**NOTICE:** the generator can work with rated output load under standard atmospheric conditions.

- "Standard atmospheric conditions" ambient temperature 25°C; Atmospheric pressure 100kPa; Relative humidity: 30%.
- The output of the generator will vary according to temperature, height (higher altitude, lower pressure) and humidity.
- When the temperature, humidity and height exceed the standard atmospheric conditions, the output of the generator will decrease.
- In addition, when used in small spaces, the load must be reduced because the cooling of the generator will be affected.

## 5.1 Starting the Generator

1. Set the fuel cock to "ON"



2. Push the choke lever to "OFF" (closed)

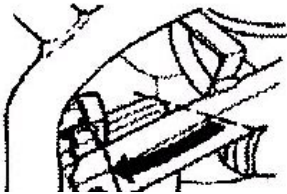

3. Turn the generator ignition switch to "ON"

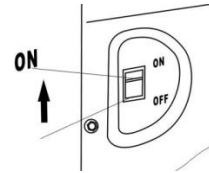

4. Pull the starter handle gently until compression can be felt then pull upwards firmly

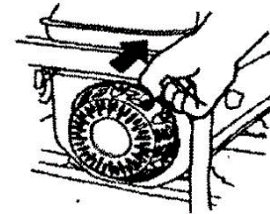

**NOTICE:** When the engine is hot, it may not always be necessary to set the "CHOKE" position when starting.

## 5.2 Stopping the Generator

**NOTICE:** turn off all connected electrical equipment.

1. Turn the energy conservation switch to "off"

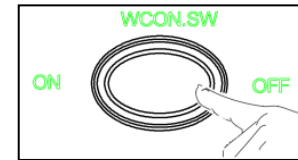

2. Disconnect all electrical equipment

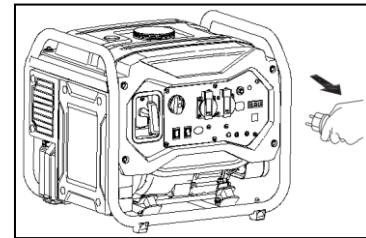

3. Switch the on/off rocker switch to the "OFF" position and ensure you have:

- a) Turned off the fuel
- b) Turned off the ignition

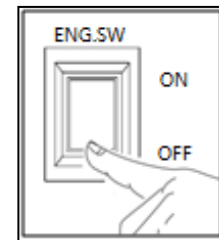

### 5.3 AC connection

**WARNING:** all electrical equipment should be disconnected before the plug is inserted.

**NOTICE:**

- Ensure that all electrical equipment, including wires and plugs, are in good condition before connecting to the generator.
- Make sure all loads being connected to the generator fall within the rated load range.
- Make sure the load current is within the rated current range of the rated socket.

**NOTICE:** Check that the unit is grounded. If the electrical equipment requires grounding, the unit must also be grounded.

1. Start the engine
2. Turn the ECS energy conservation switch to "on"
3. Insert the plug into the ac socket
4. Confirm that AC indicator is on
5. Turn on the electrical equipment

**NOTICE:** before raising engine speed, ECS Energy Conservation Switch must be turned to the "off" position. If the unit provides power for multiple loads or electrical equipment, please connect the largest to smallest according to the load size of the electrical equipment.

## 5.4 AC parallel operation (optional)

Before connecting a device to any generator, ensure that it is in good working condition and that its electrical rating does not exceed the total number of parallel generators. Most motors require more than their working current when started. When the motor is started, the overload indicator (red light) will show. Normally, the overload indicator (red light) disappears within 4 seconds. If the overload indicator (red light) stays lit, consult your generator dealer.

When running in parallel, it is necessary to ensure that the voltage and frequency of the parallel generators are the same; the ESC energy-saving switch of the two generators should be in the same position.

1. Provide the LF3500io and another LF3500io generator with its cable kit as instructed and connect the parallel operation cable.
2. Start the engine in turn to ensure that the output indicator (green light) of each generator is on.
3. Plug the device into the ac socket.
4. Turn on the device.

When the generator is overloaded or there is a short circuit in the connected equipment, the overload indicator (red light) light up. The overload indicator (red light) will remain illuminated; after about 4 seconds, the connected circuit will stop, the output indicator (green light) will disappear. The generator and the devices will stop working.

Check the problem to determine if it is due to a short circuit or overload of the connected devices, correct the problem and restart the generator.

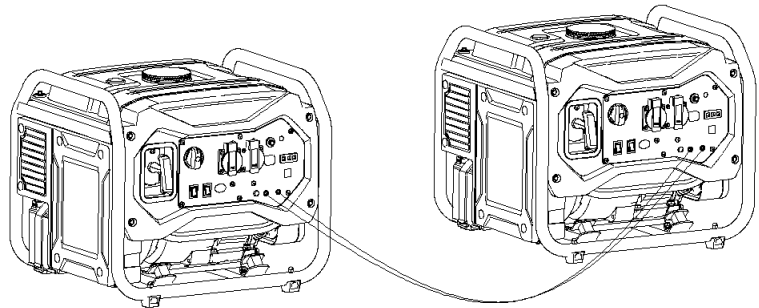

The two types of LF3500io generators (same voltage and frequency) can be connected to each other, using a parallel cable suite to increase the available power supply.

Connect the equipment or power cord to the generator first as described in the accessories to the parallel running cable kit.

**NOTICE:**

- Make sure it is in good working condition, using a wrong device or power cord may cause electrocution.
- If a device starts functioning abnormally, becomes sluggish, or stops suddenly, turn off the power immediately, disconnect the device and determine if the problem is that the rated capacity of the appliance or generator has been exceeded.
- Ensure that the electrical rating of the combined tools or equipment does not exceed that of the generator. Do not exceed the maximum limit of 30 minutes.
- The variable frequency generator with the same voltage and frequency can be connected in parallel when the load does not exceed the total output.
- In parallel operation, only the cable kit selected by our company can be run in parallel and then the LF3500io is connected in parallel with another LF3500io generator.
- Do not connect or unplug parallel operating cables while the generator is running.
- For single unit operation, the cable in parallel operation must be unplugged.

**Warning:** Continuous overloading causing the overload indicator light (red) to be continually lit, may damage the generator. Light load overload, overload indicator light (red light) flashing light, may shorten the service life of the generator.

The maximum power required for the limited operation is: 30 minutes





Maximum power for parallel operation: 6.6kva

Rated power for parallel operation: 6Kva, continuous operation, not exceeding rated power.

The requirement for total power of all connected equipment must be considered. The list of manufacturers of electrical appliances and power tools usually lists power ratings for similar models or serial Numbers.

### 5.5 Scope of application

Before using the generator, make sure that the total load is within the rated load range of the generator, otherwise it may damage the generator.

|              |   |   |  |   |
|--------------|---|---|--|---|
| AC           |  |  |  | DC<br> |
| Power factor | 1   | 0.8-0.95  | 0.4~0.75   |   |

#### NOTICE:

- When each device works on its own, it will display the number of application power.
- AC and DC can be used at the same time, the single total power must not exceed the rated output power.

**For example:**

|                        |              |        |
|------------------------|--------------|--------|
| Generator rated output |              | 3000W  |
| Frequency              | Power factor |        |
| AC                     | 1.0          | ≤3000W |
|                        | 0.8          | ≤2400W |
| DC                     | --           | 96W    |

When the total power exceeds the rated level, the overload indicator light will illuminate (see P7).

**NOTICE:**

Do not overload, the total power of the electrical equipment cannot exceed the output power of the generator, overload will damage the generator

When using this generator to supply power to precision instruments, electronic controllers, personal computers, electronic computers, microcomputers, etc., please keep sufficient distance between the equipment and the generator to prevent electromagnetic interference of the engine. It also ensures that the engine is protected from the surrounding electronics.

If this generator is used to power medical equipment, it is recommended to consult the equipment manufacturer, professional or hospital about the amount of current required to start certain electronic equipment or general motors, which may render them unusable. Even if its startup parameters meet the conditions in the above table. Please contact the equipment manufacturer

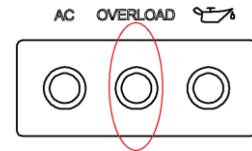

## 6.0 Maintenance

Good maintenance is the best guarantee to achieve safe, economical and zero fault operation. It also contributes to environmental protection.

The user should operate the machine safely. Periodic inspection, adjustment and lubrication can ensure the safe and efficient operation of the generator.

Warning: please turn off the engine before maintenance.

| Item                  | Routine                       | Pre-operation check (daily) | 6 months or 100 Hrs | 12 months or 300 Hrs |
|-----------------------|-------------------------------|-----------------------------|---------------------|----------------------|
| engine oil            | Check the oil level           | ✓                           |                     |                      |
|                       | Replace                       |                             | ✓ (*1)              |                      |
| Fuel                  | Check                         | ✓                           |                     |                      |
| The fuel oil pipe     | Check                         | ✓                           |                     |                      |
| Spark plug            | cleaning-adjustment           |                             |                     | ✓★                   |
| Air filter inspection | Check                         | ✓                           |                     |                      |
|                       | Clean                         |                             | ✓ (*2)              |                      |
| Fuel tank filter      | Clean or replace if necessary |                             |                     | ✓                    |
| Valve clearance       | check-adjust                  |                             |                     | ✓                    |
| Spark eliminator      | check-adjust                  |                             | ✓                   |                      |
| Cylinder head piston  | Carbon removal                |                             |                     | ★★                   |

★ These items should be replaced if necessary

★★ These items shall be maintained by the company's authorized dealers, unless the user has the appropriate tools and maintenance capabilities

**NOTICE:**

\*1-- the first oil change should be done one month before or 20 hours after operation

\*2-- air filters should be cleaned more frequently when used in damp or dusty places

- If working under high temperature or load frequently, oil should be changed every 25 hours.
- If working frequently in dusty or harsh conditions, the air filter element should be cleaned every 10 hours and replaced every 25 hours if necessary.
- The inspection period and time should be the current maintenance.
- If the maintenance cycle time has passed, it should be implemented as soon as possible according to the above table maintenance.

**Warning:**

Please stop the engine before any maintenance. The engine should be placed in a horizontal position and the spark plug cap should be separated from the spark plug to prevent the engine from starting.

Do not use it indoors or in places with poor ventilation such as tunnels and caves. Make sure that the working area is well ventilated. Exhaust fumes from engines contain the toxic gas carbon monoxide, which can cause shock, unconsciousness and even death when inhaled.

## 6.1 Spark Plug Maintenance

1. Withdraw the spark plug cap from the spark plug
2. Remove the spark plug with a spark plug spanner (counter clockwise)

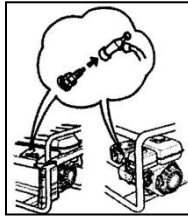

3. Remove any carbon deposits from around the spark plug and check that the porcelain central electrode colour is moderately light brown

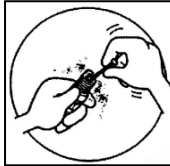

4. Check the spark plug gap with a feeler or thickness gauge, and adjust if necessary

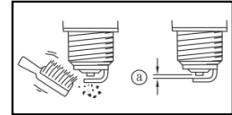

NGK spark plug: BP6ES  
Spark plug gap: 0.7-0.8mm

5. Reinstall the spark plug and tighten to the correct Nm with a torque wrench then replace cap

Torque : 22 N\*m

N.B. When installing a spark plug without a torque wrench, 'hand tight' should be sufficient temporarily. However, the spark plug should be tightened as soon as possible to the specified torque.

## 6.2 Replacing the Engine Oil

Warning: Drain the oil while it is warm, not hot. Do not drain immediately after shutting down the generator. Oil temperature is very high, be careful to avoid burns.

1. Unscrew & remove the dipstick
2. Remove the drain plug, and empty the engine oil from the crankcase into a suitable container
3. Replace the drain plug

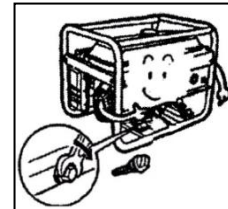
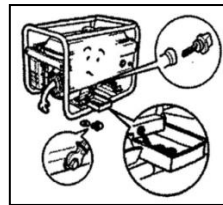
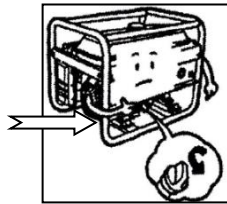

4. Fill engine oil to the upper level mark of the dipstick.

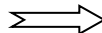
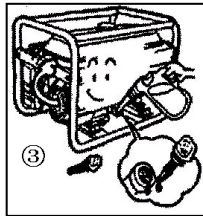

5. Reinstall the dipstick

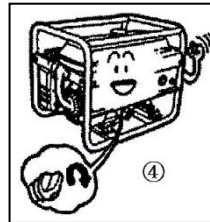

Engine oil: SAE 10W-30  
Engine oil: CLASS SE, SF from API Service Classification or SAE10W-30 engine oil equivalent to Class SG.  
Capacity: 0.6L

Note: Fill the machine on a level surface to avoid under/overfilling with oil which may cause internal damage

Do not allow foreign matter to fall into engine case.

### 6.3 Carburettor Adjustment

The carburettor is an important part of the engine. Adjustments should only be performed by someone with professional mechanical knowledge.

### 6.4 Air filter

1. Remove the screw and cover plate.
2. Remove the foam core.
3. Clean the foam filter core with solvent and dry
4. Add oil to the foam filter and squeeze out the excess. The foam filter should be wet but not dripping with oil.

Do not twist the foam filter as this will cause damage

5. Place the foam element in the air filter

#### NOTICE:

Make sure that the surface of the foam filter is close to the air filter.

Do not start the engine when the filter and cover are not in place, as this may cause excess cylinder wear.

6. Return the air filter cover to the original position and tighten the screw.
7. Replace the cover plate and tighten the screw.

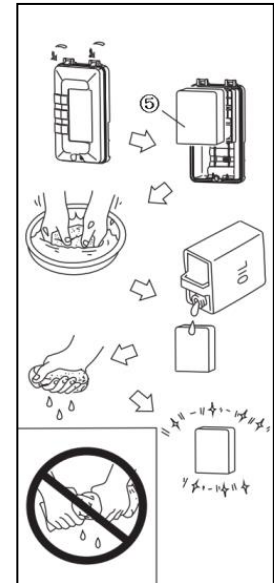

## 6.5 Muffler Mesh and Spark Collector

Warning: engine and muffler will become very hot during and after engine operation. Do not allow your skin and clothing to directly touch the engine and muffler during inspection and maintenance.

1. Remove the screw ①, remove the muffler outer cover ②
2. Loosen the bolts ③, remove muffler end bracket ④, muffler mesh ⑤, & Spark collector ⑥.
3. Use a wire brush to remove carbon deposits on muffler mesh cover and spark collector.

Note: clean with steel wire gently to avoid damage or scratching the muffler, bracket and the spark collector.

4. Check the muffler mesh and spark collector and replace them immediately if they are damaged.
5. Reinstall the spark collector.

Note: ensure the spark collector's protrusion point and the small hole of the muffler pipe are correctly aligned.

6. Replace the muffler mesh and bracket.
7. Reposition the muffler outer cover and tighten the screw.

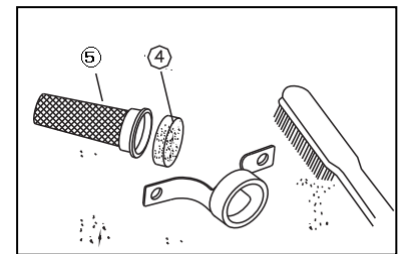
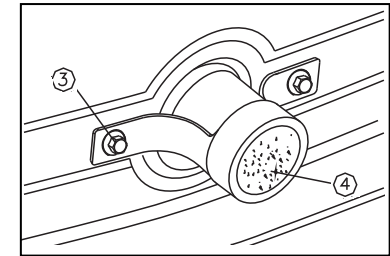
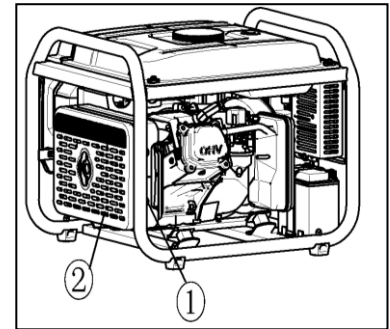

## 6.6 Fuel tank filter

**Warning:** do not use petrol where there is smoke or flame.

1. Remove fuel tank cap and strainer.
2. Clean the fuel tank strainer with petrol.
3. Dry the strainer and return to the fuel tank.
4. Replace the fuel tank cap.

**NOTICE:** Ensure the fuel cap is screwed on correctly.

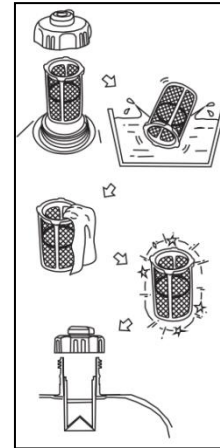

## 7.0 Storage

If you plan to store this generator unused for a long period, you will need to take some storage measures to prevent the internal components corroding.

### 7.1 Removing the fuel

1. Turn the fuel off
2. Remove the tank cap and strainer. Syphon most of the fuel from the tank into a suitable storage container and replace the tank cap.

**Warning:** Fuel is highly flammable and toxic. Please read the safety instructions carefully (see page 1).

Note: Use a clean, soft cloth to immediately wipe away any spilled fuel.

3. Start the engine (see page 16), and allow the engine to run out of fuel.

- Do not connect any electrical equipment
- The running time of the engine depends on the fuel remaining in the tank

5. Loosen the drain bolt on the carburetor and drain any remaining fuel from the carburetor into a suitable container.

7. Tighten the drain bolt.

## **7.2 Engine storage**

Follow the steps below to protect the box, piston ring and other corrosion-prone parts.

1. Remove the spark plug, pour in approx. 15ml (1 tblespn) of SAE10W30 oil, replace the spark plug, pull and release the recoil handle slowly several times to lubricate the cylinder block with the oil
2. Pull the recoil starter gently until you reach compression and release slowly. This protects the cylinder, head and valves from rusting.
3. Clean the outer surface of the unit with a soft, clean cloth; place in a dry, well-ventilated place and cover with a protective sheet

## 8. Troubleshooting

### The engine does not start

#### 1. Fuel system

There is no fuel in the combustion chamber:

No fuel in the tank → Refuel

There is fuel in the tank → check the fuel cap  
vent is open

Clogged fuel filter → Clean the fuel filter

Carburettor is blocked → Clean the carburetor

#### 2. Oil system insufficient

Oil level is too low → Refill the oil

#### 3. Electrical system

Combination switch to "choke", hand recoil starter

normal, Spark plug has no spark.

Spark plug may have deposits of carbon or moisture

→ Check, Clean and dry spark plug or replace.

Ignition system problem → Please contact  
your distributor

The generator has no voltage output:

Safety device (dc protector) in "OFF" position →  
switch the dc protector to the "ON" position.

Ac indicator light (green) off → Stop the engine  
and restart or press the voltage recovery button for  
1-3 seconds to restore the voltage output.

## 9.0 Parameters

|                  |                       | Model No. | KP3500iO-2                                   |  |
|------------------|-----------------------|-----------|--|--|
| <b>Generator</b> | Type                  |           | Inverter                                     |  |
|                  | Rated frequency/Hz    |           | 50/60  |  |
|                  | Rated voltage/V       |           | 220/230/120V                                 |  |
|                  | Rated output power/Kw |           | 3.0  |  |
|                  | Max. output power /Kw |           | 3.3  |  |
|                  | Power factor          |           | 1  |  |
|                  | DC output /V-A        |           | 12V-8A                                       |  |
|                  | AC output quality     |           | ISO8528 G2                                   |  |
|                  | THD/%                 |           | 3  |  |
|                  | Noise /dB             |           | 68   |  |
|                  | Overload protect      | DC        | Non-fuse protector                           |  |
|                  |                       | AC        | Control by inverter overload protect program |  |

|                      |                         |   |
|----------------------|-------------------------|---|
| <b>Engine</b>        | Engine Model            | 170F  |
|                      | Engine type             | Single cylinder, 4-stroke, forced air cooled, OHV |
|                      | Displacement/cc         | 212   |
|                      | Fuel type               | Unleaded petrol                                   |
|                      | Fuel tank capacity/L    | 10  |
|                      | Continue running time/h | 5.5   |
|                      | Engine oil capacity     | 600ml   |
|                      | Spark model No.         | NGK CR5HSB  |
|                      | Starting mode           | Hand Recoil/E-start                               |
| <b>Generator set</b> | L×W×H/mm                | 423*434*474                                       |
| Net weight/Kg        |                         | 30  |

# 10.0 Wiring diagram -220V 50Hz

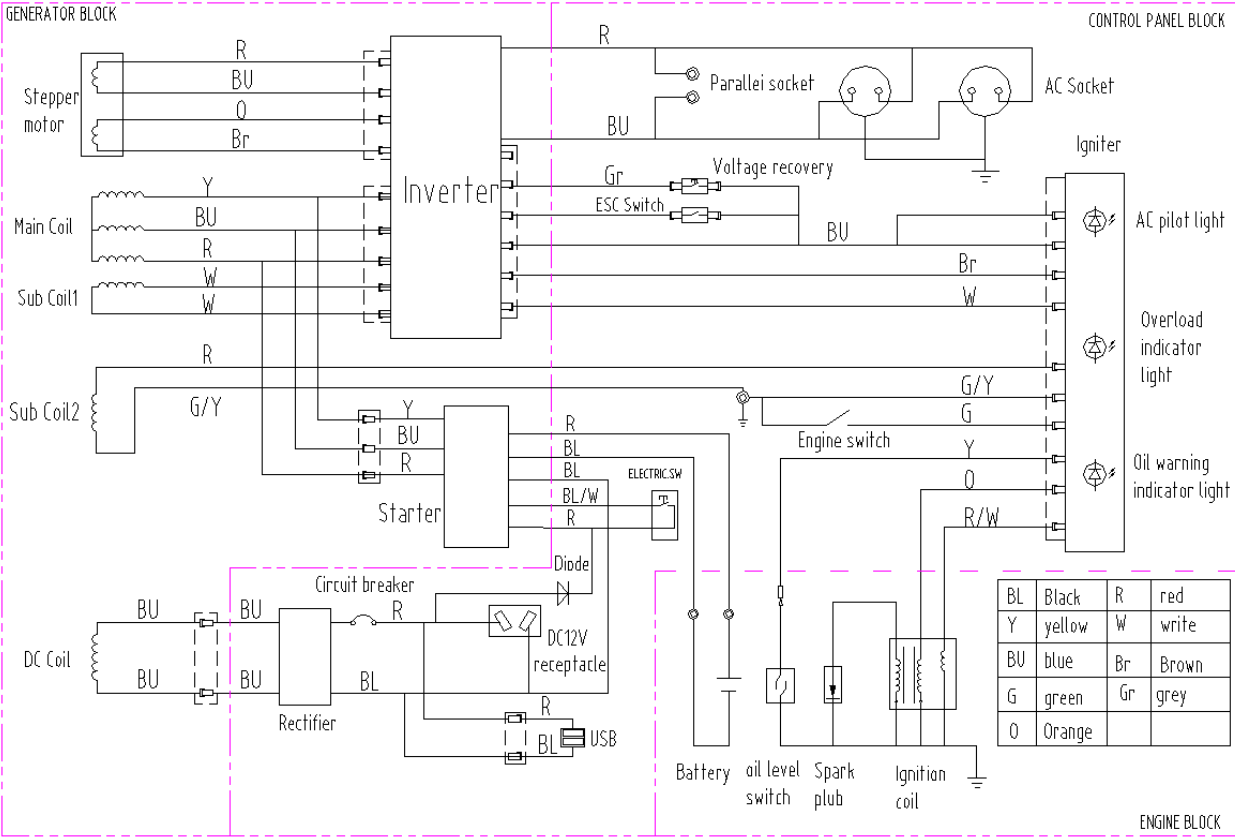

# 120V 60Hz

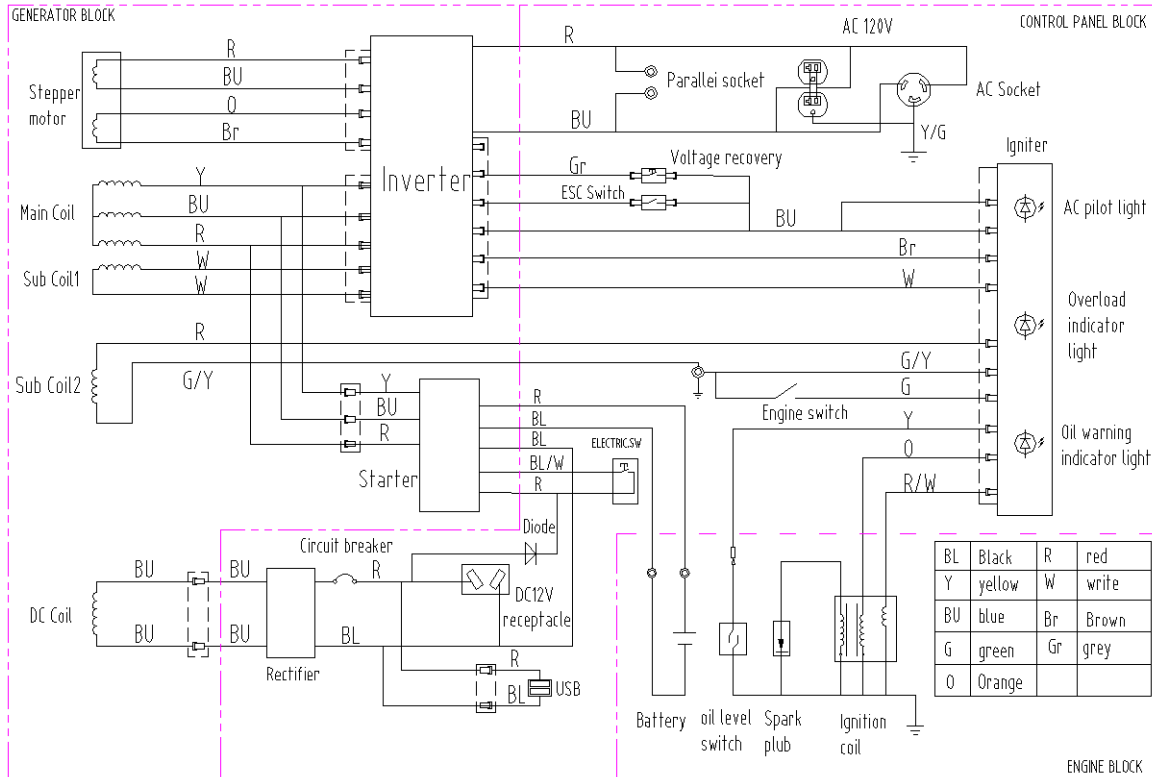

Y0-162