

LIFAN

**OPERATING INSTRUCTIONS
FOR
GASOLINE WATER PUMP SET**

LF80SP

CHONGQING LIFAN SUZHUI FOREIGN TRADE CO.,LTD.

PREFACE

Thank you for choosing a water pump set by our company.

Based on the latest technology at home and abroad, our Co. has individually developed the water pump set. The unit is characterized by advanced design, compact structure, great power, convenient service, low fuel consumption and noise. They are widely used as ideal equipment in many fields such as agriculture, gardening, building industry, etc.

The manual gives information with respect to operation and maintenance of the water pump set, and be sure to read it carefully first before operating. All the materials and diagrams laid down in this manual are in accordance with the newest products at the publishing time. Due to revision and other change, the information described in this manual may be a little different from the actual status. The copyright of this manual belongs to our Co., any group or individual is forbidden to reprint or copy any it. The manual is subject to change without notice.

Please pay special attention to statements preceded by the following words.

IMPORTANT NOTICES

Please pay special attention to statements preceded by the following words:



WARNING:

A warning is used to alert the user to fact that hazardous operating and maintenance procedures may result in injury to or death of personnel if not strictly observed.



CAUTION:

A caution is used to alert the user to fact that hazardous operation and maintenance procedures may result in injury to or death of personnel if not strictly observed.

NOTE:

Give helpful information.

This manual is filled with important safety information — please read it carefully.

This manual should be considered as a permanent part of the water pump set and should remain with the water pump set when resold.

CONTENTS

1. Safety General Rules.....	4
2. Parts Description.....	6
3. Pre-Operate Preparation.....	7
4. Operation	13
5. Stopping.....	16
6. Maintenance.....	17
7. Starting up in plateau regions	22
8. Transportation and Storage	23
9. Troubleshooting	25
10. Specifications.....	27

1. SAFETY GENERAL RULES

Before operating, read the manual carefully and be sure to become familiar with it, otherwise personal injury of death as well as severe parts damage may occur.

- Before operating, perform the pre-operation inspection to make your operation on the water pump safer.
- For the sake of safety, it is forbidden to pump inflammable or corrosive liquids (such as gasoline or acid). Similarly, be sure not to pump corrosives such as seawater, chemical solution, alkaline liquids.
- Locate the water pump on a firm and level ground. A sloped or overturned water pump may result in fuel spilled out.
- Operate a water pump in a well-ventilated place without fire resources and keep it at least one meter from other devices.
- Because touching hot parts of the engine may get severe burns when operating the water pump, keep children and pets far away from the operating site.
- Master the method to quick stop the water pump; learn manipulating control devices. Using the water pump without following the instructions in the manual is forbidden.

⚠ WARNING

- *Gasoline is extremely flammable and explosive in certain conditions.*
- *Filling gasoline in a well-ventilated place with engine stalled. In gasoline filling and storage sites, be sure there are no smoking and fire resources such as flame, fire spark and so on.*
- *Do not spill gasoline out of the fuel tank. After filling, make sure to tighten the fuel filler cap.*
- *When filling, avoid spilling gasoline out, for spilled gasoline and gasoline vapor is prone to ignite. Once gasoline is spilled out, make sure to wipe it up before operation.*
- *Don't run the engine in an enclosed room and poor-ventilated place, since exhaust emission from the engine contain toxic carbon monoxide (CO), which may make people lose consciousness, even lead to death.*

2. PARTS DESCRIPTION

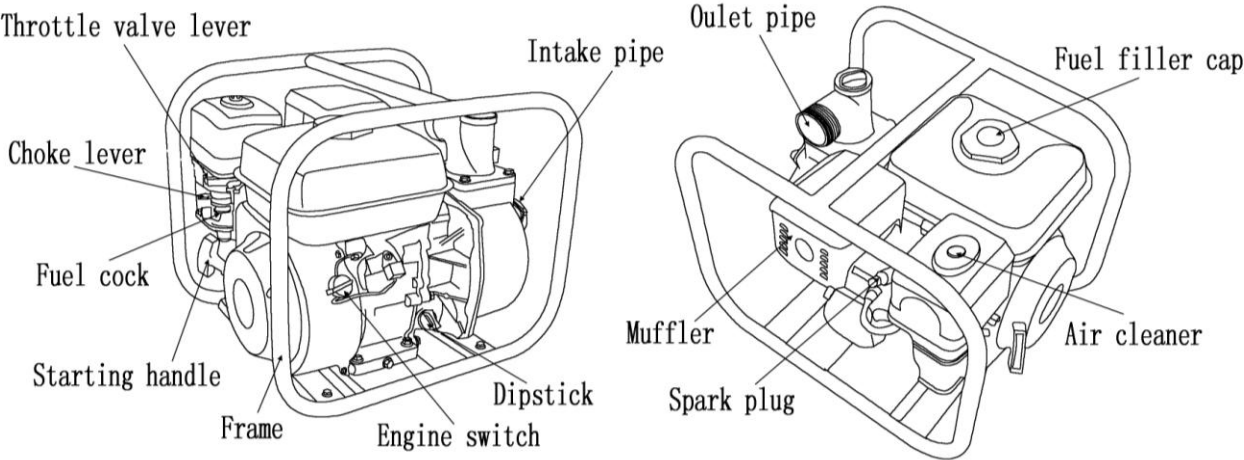

(Fig.1)

3. PRE-OPERATION PREPARATION

3.1 Connecting water inlet pipe

Use commercially available hose, hose joint and clamp. The water inlet hose must be of continuous structure and be non-folded. The length of the hose should be as the same as or not more than that required. The effect of suction is greater the shorter distance from the water surface. Suction time varies with the length of the water inlet hose in direct ratio. The filter matching with the water pump should be mounted to the end of the water inlet hose with a hose clamp.

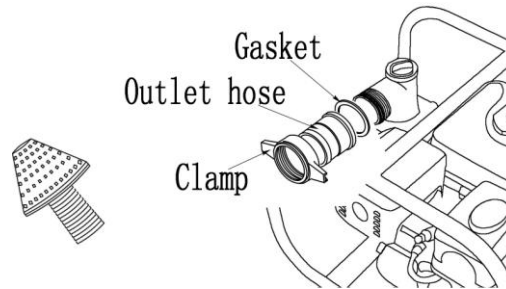

(Fig.2)

⚠ CAUTION

- *Before pumping, install the filter securely to the end of the water inlet hose. The filter filtrates any impurity, which may produce passage jam to damage impellers.*
- *Be sure to install the hose joint and clamp well so as to prevent from air leaks and pumping performance drop; loose water inlet hose will decrease the water pump performance and self-suction ability.*

3.2 Connecting the water outlet hose

Use commercially available hose, hose joint and clamp. A short hose with a big diameter is the best. A long hose with small diameter will increase flowing resistance and decrease the power output of the water pump.

NOTE

Tighten the hose clamp to avoid falling off under high pressure.

3.3 Engine oil level check

⚠ CAUTION

- *The quality of the engine oil is one of the key factors in deciding engine performance and service life. Not apply filthy engine oil or vegetable oil.*
- *Be sure to check engine oil level with the engine stalled and stand vertically in level ground.*

Use 4-stroke gasoline engine oil equivalent in quality with SF, SG from API.

Oil velocity varies with average temperature, so select engine oil with proper velocity in accordance with your region temperature.

▲ ENGINE OIL ALARM SYSTEM

The engine oil alarm system is intended to avoid engine damage due to too less engine oil in the crankcase.

Before the engine oil level in the crankcase drops down below the safety line, the alarm system will tell the engine automatically (while the engine switch keeps at ON).

If the engine stops and cannot restart, check the engine oil level first and then to others.

Remove the engine oil dipstick and wipe it clean; insert the dipstick into engine oil filler hole without screwing it in, and then take out to check the engine oil level; if the engine oil level is too low, fill specified engine oil up to the top of the filler hole.

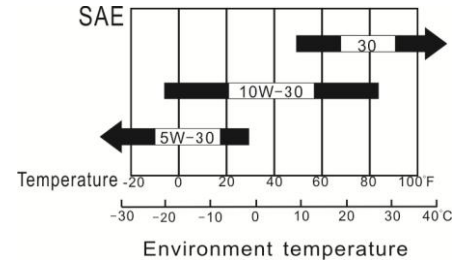

(Fig.3)

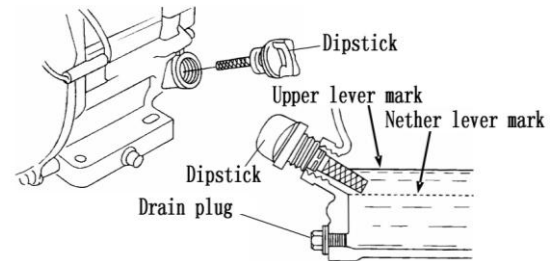

(Fig.4)

⚠ CAUTION

Runs with insufficient engine oil can damage the engine severely.

3.4 Check fuel level

Remove the fuel tank cap and check the fuel level, If the fuel level is too low, refuel more.

Only use specified gasoline in the manual (Recommend to use unleaded gasoline).

Do not use the combination of engine oil and gasoline or filthy gasoline. Avoid dirt, dust and water into the fuel tank.

Fuel tank capacity

LF80SP.....6.0L

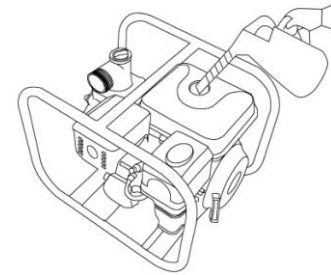

(Fig.5)

⚠ WARNING

- *Gasoline is extremely inflammable and explosive in certain conditions.*
- *Refueling in a well-ventilated area with the engine stalled. In places refueling or fuel storage, no smoking, flames and spark.*
- *Do not spill fuel out of the fuel tank (no gasoline in fuel filler neck), after refueling, make sure to mount the fuel tank cap securely.*

- *When refueling, be careful not to spill gasoline. Spilled gasoline and gasoline vapor may ignite. If there is spilled gasoline, be sure to wipe it dry before starting the engine.*
- *Avoid repeated or sustained breathing and touch with skin.*
- *Keep out of reach of children.*

3.5 Air cleaner filter element check

Dismantle the thumbnut, washer and air cleaner cover.

Check the filter element, if too filthy or clogged, clean it.

⚠ CAUTION

Do not run the engine without the air cleaner installed, otherwise dirt, dust and so on will be inhaled into the engine through the carburetor, resulting in premature wear of the engine.

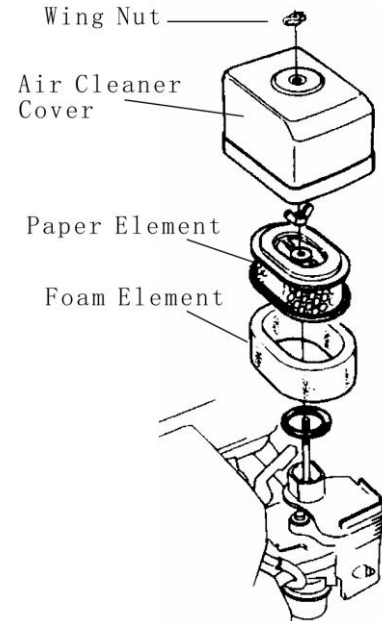

(Fig.6)

3.6 Water capacity check in the pump

Before operating the pump, make sure to fill the pump with enough water.

⚠ CAUTION

Do not try to run the engine without water inside, otherwise the pump will become overheated. Prolonged running of the pump without water will damage the pump gasket. If the water in the pump is used up, stall the engine at once and fill the pump once it cools down.

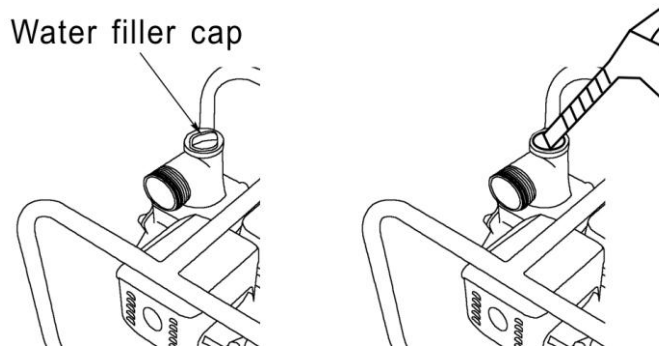

(Fig.7)

4. OPERATION

4.1 Before operation

For your safety, and to maximize the service life of your equipment, it is very important to take a few moments before you operate the pump to check its condition. Be sure to take care of any problem you find, or have your servicing dealer correct it, before you operate the pump.

Before beginning your preparation checks, be sure the pump is on a level surface and the engine switch is in the OFF position.

To prevent fire hazards, keep the pump at least 1 meter (3 feet) away from building walls and other equipment during operation. Do not place flammable objects close to the engine.

Exhaust gas contains poisonous carbon monoxide. Avoid inhalation of exhaust gas. Never run the engine in a closed garage or confined area.

CAUTION

Improperly maintaining this pump, or failing to correct a problem before operation, could cause a malfunction in which you could be seriously injured.

Always perform a preparation inspection before each operation, and correct any problem.

4.1.1 Check the Condition of the Pump

Look for signs of damage.

Look around and underneath the pump for signs of oil or gasoline leaks.

Remove any excessive dirt or debris, especially around the engine muffler, and recoil starter.

4.1.2 Check the Suction and discharge Hoses

Check the general condition of the hose. Be sure the hoses are in serviceable condition before connecting them to the pump. Remember that the suction hose must be reinforced construction to prevent hose collapse.

Check that the sealing washer in the suction hose connector is in good condition.

Check that the hose connectors and clamps are securely installed.

Check that the filter is in good condition and is installed on the suction hose.

4.1.3 Check the engine

Check the oil level. To avoid the inconvenience of an unexpected shutdown by the engine oil alarm system, always check the engine oil level before startup.

Check the air cleaner. A dirty air cleaner will restrict air flow to the carburetor, reducing engine and pump performance.

Check the fuel level. Starting with a full tank will help to eliminate or reduce operation interruptions for refueling.

4.2 Starting the Engine

4.2.1 Prime the pump.

4.2.2 Move the fuel cock to the **ON** position.

4.2.3 To start a cold engine, move the choke level to the **CLOSED** position. To restart a warm engine, leave the choke level in the **OPEN** position.

4.2.4 Move the throttle valve level away from the **LOWER** position, about 1/3 of the way toward the **UPPER** position.

4.2.5 Turn the engine switch to the **ON** position.

4.2.6 Pull the starter handle lightly until resistance is felt, then pull it briskly. Do not allow the starter handle to snap back against the engine. Return it gently to prevent damage to the starter.

4.2.7 If the choke lever was moved to the **CLOSED** position to start the engine, gradually move it to the **OPEN** position as the engine warms up.

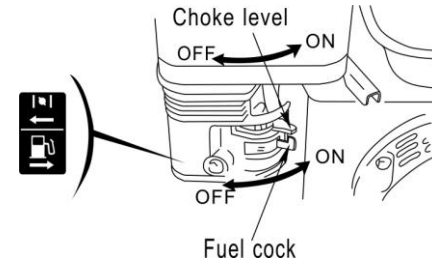

(Fig.8)

4.3 Setting Engine Speed

After starting the engine, move the throttle valve lever to the **UPPER** position for self-priming, and check pump output.

Pump output is controlled by adjusting engine speed. Moving the throttle valve lever in the **UPPER** direction will increase pump output, and moving the throttle valve lever in the **LOWER** direction will decrease pump output.

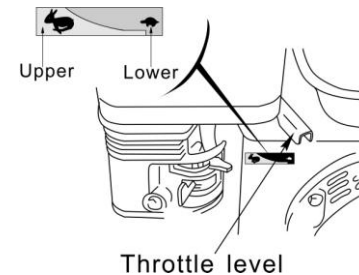

(Fig.9)

5. STOPPING

To stop the engine in an emergency, simply turn the engine switch to the **OFF** position. Under normal conditions, use the following procedure.

5.1 Move the throttle valve lever to the **LOWER** position.

5.2 Turn the engine switch to the **OFF** position.

5.3 Turn the fuel cock to the **OFF** position.

After use, remove the water drain plug, and drain the pump chamber. Remove the water filler cap, and flush the pump chamber with clean, fresh water. Allow the water to drain from the pump chamber, then reinstall the water filler cap and water drain plug.

NOTE

Stalling the engine in emergency, turn the engine switch to OFF position.

6. MAINTENANCE

To keep the water pump at optimal performance, check and adjustment on it periodically is necessary. Regular maintenance and service may extend its service life obviously. The Maintenance Schedule below specifies how often you should have your water pump served, and what things need attention.

⚠ WARNING

Before maintenance, stall the engine. If maintaining the engine when it runs, make sure to perform any check in a well – ventilated area. Exhaust emissions from the engine contains toxic carbon monoxide (CO), which may cause loss of consciousness and even life.

Maintenance Schedule

Frequency		Before each use	First month or 20 Hrs.	First 3 month or 50 Hrs.	First 6 month or 100 Hrs.	First year or 300 Hrs.
Item						
Engine oil	Oil level	○				
	Oil change		○		○	
Air cleaner	Check	○				
	Clean					
Spark plug				○(1)		○(2)
Valve clearance						○(2)
Clean combustion		Every 500 Hrs.				
Spark eliminator		Every 100 Hrs.				
Fuel tube		Every 2 years				
Impeller check						○(2)
Water pump tank cover						○(2)
Water inlet valve check						○(2)

NOTE

(1) Use in extremely dusty area, the job should be done more often.

(2) Should be done by your dealer, unless you are equipped with proper repair tools, and are qualified mechanically.

⚠ WARNING

Before maintenance and service, stall the engine. If maintaining when the engine runs, make sure to perform any check in a well-ventilated area. Exhaust emissions from the engine contains toxic carbon monoxide (CO), which may cause loss of consciousness and even life.

6.1 Engine Oil Replacement

A warm-up engine can assure quick oil draining.

- 1.Remove the dipstick and drain plug, and then drain the oil.
- 2.Fill specified fresh engine oil to oil.
- 3.Reinstall the dipstick and tighten it.

Oil capacity:

LF80SP..... 1.1L

Once touch engine oil, clean your hands with soap in fresh water.

NOTE

Handing discarded engine oil in accordance with relative environmental protection rules. It's better for you to take it in a sealed container and take to local recycling station. Do not pour at will.

6.2 Air Cleaner Maintenance

A filthy air cleaner will decrease airflow quantity through the carburetor. To avoid troubles of the carburetor, clean the air cleaner regularly. In extremely dusty area, the job should be done more often.

WARNING

Never clean the air cleaner in gasoline or low-flash point solvent, for gasoline and low-flash point solvent may produce flames and even an explosion in certain conditions.

CAUTION

Never operate the water pump without the air cleaner installed. In the case that dirt and dust is sucked into the engine, the engine will wear out more quickly.

6.2.1 Drive off the thumbnut and dismantle the air cleaner cover and filter element.

6.2.2 Clean the filter element in high flash point solvent or cleansing solvent thoroughly, and then dry it up.

6.2.3 Soak the filter element in clear engine oil, and then squeeze out excessive oil.

6.2.4 Reinstall the removed parts well.

6.3 Spark Plug Maintenance

Recommended spark plug

LF80SP.....NHSP LD F6TC

To keep the engine in good condition, there must keep proper spark plug clearance and no accumulated carbon.

6.3.1 Dismantle the spark plug cap.

WARNING

When the engine is running, the exhaust muffler is very hot, be careful not to get burns.

6.3.2 Check the spark plug just with eyes. If there exists obvious wear sign around it or gasket is cracked, please replace with a new one. Before reinstall a spark plug, clean it first with a wire brush.

6.3.3 Measure spark plug clearance with a feeler gauge and adjust it by bending the side electrode. Spark plug clearance should be 0.70~0.80 mm.

6.3.4 Check that the spark plug gasket is in good condition, or replace with a new one. Drive it into the engine with a spark plug wrench to protect thread from being damaged.

NOTE

Installing a new spark plug, after it touch and oppress the gasket, twist 1/2 more turns; as to a used one, twist 1/2~1/4 more turns.

⚠ CAUTION

Be sure to tighten the spark plug securely, otherwise it may become very hot and possibly damage the engine. Never use a spark plug with improper heat range.

7. STARTING UP IN PLATEAU REGIONS

In plateau or regions with high altitude, standard carburetor produces over-dense combination of fuel and air, resulting in decreased engine performance and increased fuel consumption. To keep the engine with high performance, install a carburetor main spray nozzle and readjust the adjusting screw for idle speed. Using in plateau regions frequently with an altitude of over 1380 m, contact your dealer for replace the carburetor and make adjustment in advance. Even though a proper carburetor spray nozzle is installed in the engine, the power output of the engine will drop about 3.5% with every 305 m increase in altitude. If carburetor replacement and adjustment is not done, the “plateau-effect” will be more severe then that done.

⚠ CAUTION

Use the water pump in regions with lower altitude than that the carburetor spray nozzle is applicable, the engine performance will decrease and become overheated, and over-thin combination of fuel and air produce may cause sever damage of the engine.

8. TRANSPORTATION/STORAGE

⚠ WARNING

To avoid a fire, make sure to allow at least 20 minutes to cool the water pump down before transportation or storage in room.

Transport the water pump with the fuel cock turned off, besides, keep it horizontal to prevent fuel from spilling. Spilled gasoline and gasoline vapor may ignite.

8.1 Make sure the storage site for the water pump is dry and clean.

8.2 Clean the water pump inside.

If the water pump is used to pump water with mud, sand or heavy debris, deposit of such may remain inside it. Before storage, operate the water pump to suck into fresh water to wash, otherwise impeller may be damaged once reuse. Finishing wash, drive off the water drain plug, then empty the water in the water pump thoroughly, and reinstall the water drain plug.

8.3 Empty fuel inside the fuel tank.

⚠ WARNING

Gasoline is extremely flammable and explosive in certain conditions.

a. Turn the fuel cock to OFF position, drive off the fuel drain plug of the carburetor floater room, drain out the fuel in the carburetor. Hold drained gasoline in proper container.

b. Turn the fuel cock to ON position.

c. Reinstall the fuel drain plug of the carburetor floater room.

8.4 Replace engine oil.(see page 10)

8.5 Dismantle the spark plug, and fill clean specified engine oil into the cylinder about one soupsoon. Turn the engine several times to distribute oil evenly and then reinstall the spark plug.

8.6 Pull the starter handle towards until feel anti-action, and then continue pulling until the triangle mark on the starter wheel lines up with the starter screw hole (see diagram below). In this location, both the air inlet and exhaust valves are closed, which may prevent the engine inside from rusting.

8.7 Cover the water pump to protect from dust.

9. TROUBLESHOOTING

9.1 Engine cannot start

Check according to the following:

9.1 Check if there is enough fuel;

9.2 Check if the fuel cock is turned on;

9.3 Check if the fuel enters the carburetor;

In the case that the fuel cock is turned on, check through dismantle the fuel drain plug at the bottom of the carburetor.



WARNING

Gasoline is extremely inflammable and explosive in certain conditions.



WARNING

If fuel is spilled, be sure to wipe it dry before checking the spark plug and starting up the engine, otherwise spilled fuel or fuel vapor may ignite.

4. Check if the engine switch is at **ON** position;

5. Check if there is enough engine oil the crankcase;

6. Check if there is spark plug spark;

a. Dismantle the spark plug cap. Clear away dirt around the spark plug, and then dismantle it.

b. Install the spark plug into the spark plug cap.

c. Turn the engine switch at **ON** position.

d. Earth the side electrode by touching the engine, pull the kick-starter to check if there is spark.

e. If no spark, please start the engine according to “Starting the Engine” in the manual.

7. If the engine still cannot start, contact your dealer for help.

9.2 Water pump cannot pump

Check according to the following:

1. Check if there is enough water;

2. Check if the filter is clogged;

3. Check if the hose clamp is tighten securely;

4. Check if the water hose is damaged;

5. Check if suction height required is too high;

6. If the water pump still cannot pump water, please contact your dealer for help.

10. SPECIFICATIONS

MODEL		LF80SP
Engine	Model	177F
	Type	4-stroke OHV single cylinder with force air-cooled
	Displacement	270cm ³
	Bore × Stroke	77 × 58mm
	Power	5.4kW/3600rpm
	Ignition system	Non-contractor transistorized ignition (TCI)
Water Pump	Inlet/Outlet dia.	80mm(3.0in)
	Rotation velocity	3600r/min
	Self-suction head	5m
	Pump lift	27m
	Pump output	72m ³ /h
	Duration of runs	2.0h
Complete Unit	Length	700mm
	Width	455mm
	Height	545mm
	Net weight	62kg

K-2064

